

D1S

550T-4000T

D1S SERIES
TWO-PLATEN INJECTION MOLDING MACHINE



Yizumi Precision Molding Technology Co., Ltd.

Address: No.12 Shunchang Road, Shunde, Foshan, Guangdong 528300, China
TEL: 86-757-2921 9764 86-757-2921 9001(overseas) Email: imm@yizumi.com
www.yizumi.com

[DISCLAIMER]

- [1] YIZUMI reserves the right to modify the product description in the catalogue. Specification might be changed without prior notice.
 - [2] The picture in the catalogue is for reference only. The real object should be considered as final.
 - [3] The data in the catalogue is obtained from internal testing in YIZUMI laboratory.
- Please refer to the actual machine for the final data. YIZUMI reserves the right of final interpretation upon disputes and ambiguities.



THINK TECH FORWARD

D1S

PRODUCT DETAILS

PRODUCT DETAILS

Based on importation and absorption of advanced German technology and years of experience in product application, we continue to move on and undertake the historic project of large-tonnage two-platen injection molding machine, striving to become a pioneer to fulfill such an innovative mission.



Deep-cavity parts



Household appliances

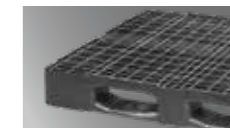

Logistics materials

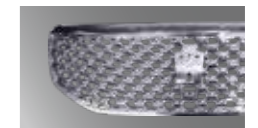

Auto parts



Auto bumper



Auto sunroof



Interior trim



Car light

THINK TECH FORWARD

More effective

Quick response hydraulic cylinders, synchronized lock nut mechanism, differential fast mold opening, precision movable platen supports, low-resistance hydraulic circuit design and high-response servo system enable the machine to operate more efficiently and response faster.

More energy-saving

The moveable platen has zero contact with the tie bars, also the clamping cylinder is assembled on the fixed platen, thus there is little load for moveable platen and less resistance could be caused during mold opening and closing, more energy saving. What's more, new-generation oil cooling servo system and PID temperature control are equipped to make machine more energy-efficient.

Smaller footprint

Compact design, automatic tie-bar extraction device for option to ensure machine is not limited by the height of workshop.

More functions in control system

D1S series adopts Austria's KEBA control system, with double CPUs, enabling fast response and various functions. New processes like MuCell, ICM (injection compression molding), IMC (In-Mold-Coatings) can be integrated.

Shorter dry cycle

Quick response hydraulic cylinders, synchronized lock nut mechanism, fast and stable mold opening.

More stable injection precision

The full closed-loop function for injection control and PID temperature control ensure repeatability of part weight < 0.3%.

More stable

High-rigidity clamping unit, uniform stress distribution on tie bar threads, high-response dual proportional valve, smart closed-loop control, precision filter and efficient cooling system enable the machine to be more precise and stable for injection molding.

Sensitive mold protection

With the low-resistance hydraulic circuit and pressure sensor, even three pieces of A4 paper can be sensed. Low-pressure mold protection is more reliable and sensitive.

More balanced force of tie bar

The tie bars adopt the uniform stress technology thus each thread is evenly stressed without unbalanced loading, durable and reliable. And it needs no lubrication, be cleaner.

Higher repeatability of mold-open end position

Fast response and high repeatability thanks to the high-response dual proportional valve control technology, which can meet strict requirement from automatic picking.

More energy-saving servo system

New-generation oil cooling servo system is stable, reliable and durable and characterized by high efficiency, energy saving, low noise, strong power and fast response.

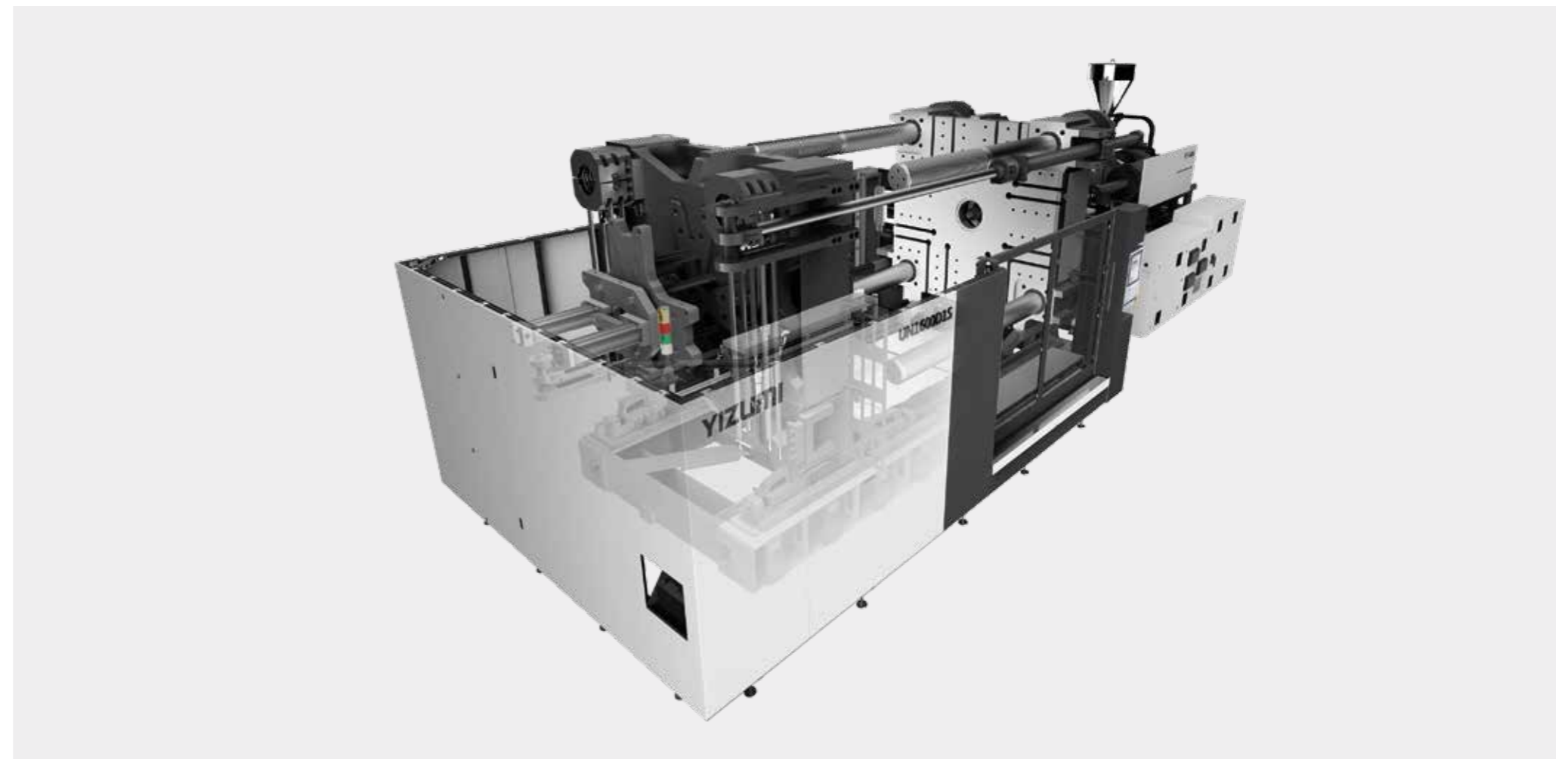

CLAMPING UNIT



Short dry cycle, reliable and stable

D1S series two-platen injection molding machine, based on high-rigidity clamping unit, precision guide device, synchronized lock nut mechanism, quick response hydraulic cylinders, fast control system and controlled by high-response dual proportional valve, delivers higher movement efficiency and control stability.

Impact-proof synchronized lock nut mechanism

Impact-cushioning synchronized lock nut closing is fast and more reliable with low noise.



Independent high-pressure cylinder

Mold opening under high pressure for standard. Large opening force can solve molding problems of deep-cavity products or car lights which are strongly coated on mold or have difficulty in mold opening.



Highly-rigid accurate guide device

Long movable platen supports and L-shape guide rails on machine frame facilitate high load-bearing, guide capacity, and anti-roll adjustment.



Tie bars with uniform stress distribution

Tie bars are highly-rigid and resistant to wear and corrosion. Uniformity of stress distributed on tie bar threads is over 99% without unbalanced force, bringing durability.



INJECTION UNIT

Stable injection end position High repeatability of part weight

Linear guide rails, with the benefits of low resistance and quick acceleration, are a standard feature of DIS series two-platen injection molding machine. Incorporating other features, such as ultrasonic displacement sensor for monitoring and full closed-loop injection, DIS series has achieved accurate position control and high repeatability of part weight.



Excellent injection repeatability

Repeatability of injection end position up to $\pm 0.2\text{mm}$ or less and repeatability of part weight $\leq 0.3\%$.

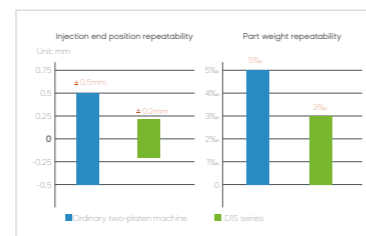

Integral linear guide rails for injection

Linear guide rails are a standard feature of DIS series, bringing benefits of low resistance, quick acceleration and stable injection.



Non-contacted ultrasonic displacement sensor

Ultrasonic displacement sensor for position measurement is characterized by little signal interference, long service life and high accuracy of measurement.



Adaptive PID temperature control

With the use of durable ceramic heater bands and adaptive PID control performed by the Austrian controller, temperature control accuracy is up to $\pm 0.5^\circ\text{C}$.



HYDRAULIC SYSTEM



Fast response, strong overloading, stability, energy conservation

D1S series is based on a hydraulic system with stability and fast response at the core, which enables hydraulic circuit to be in optimal operating conditions. The hydraulic system is characterized by fast response, strong overload capacity and low energy consumption that meets China energy efficiency grade 1.

New-generation servo system driven by fully oil-cooled motor

The fully oil-cooled two-headed motor-driven servo system is the quintessence of highly-integrated servo pump system. It eliminates the influence of instability in machine operation due to the work environment and further reduces energy consumption of hydraulic circuit. Synchronized drive technology makes hydraulic circuit response faster and movements more efficient.

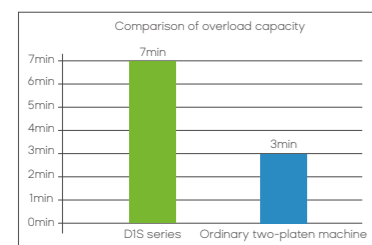

Strong overload capacity

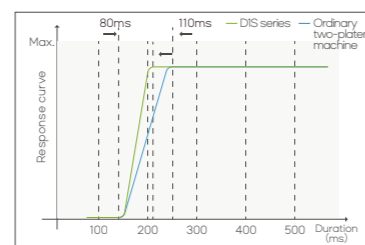

Rapid acceleration



Durable and reliable

Precise filtration and independent cooling system

With independent hydraulic circuit filtration system, filter fineness is up to 5µm and cooling effect is optimized, which ensure long service life of seals. Machine becomes more stable.



Good cooling effect



High filter fineness

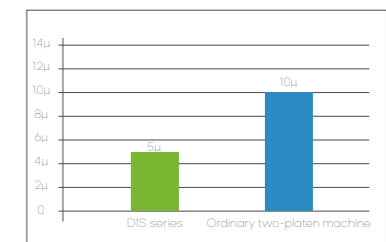

Comparison of filter fineness

Motor protected with L-shape plates

L-shape plates are easy to install and can be opened directly so that there is open space for more efficient maintenance of the drive system.



CONTROL SYSTEM

Accurate control, various functions, reliable and stable

D1S series adopts Austria's KEBA control system dedicated to two-platen injection molding machine. This powerful system can accurately control the position, pressure, speed, temperature and other parameters. The whole control system is engineered based on reliability, stability, safety and user-friendly operation for better user experience.



Stable, fast and accurate control

- ▶ D1S series injection molding machine adopts Austria's KEBA control system, with double CPUs, 1ms of response time and high reliability.
- ▶ Fast mold opening and closing and high repeatability thanks to the high-response dual proportional valve control technology.
- ▶ Servo injection (closed-loop control of injection, plasticizing, holding pressure and back pressure)
- ▶ Self-tuning of temperature parameters of barrel and hot runner makes temperature control more accurate.

Various functions

- ▶ Memory of alarm and process parameter change, USB expansion without limit
- ▶ Programming with no restrictions, record of process parameter change curve is available
- ▶ Production process data control (PDP) and statistical process control (SPC)
- ▶ Multi-level user access to protect system and data
- ▶ Multiple protections of equipment and people through software and hardware
- ▶ New processes like MuCell, ICM, IMC can be integrated

Humanized design, easy to operate

- ▶ Real-time remote control and maintenance
- ▶ Online conversion of languages and units
- ▶ Quick input by means of graph and virtual keyboard
- ▶ Quick settings page for easy and convenient process parameter setting



IP54 electrical enclosure

The electrical enclosure is designed with IP54 rating, resistance to water and dust and good cooling effect, so that the electrical system is more stable in operation.



Separate connector module for auxiliary equipment

External separate power control without opening the electrical cabinet makes operation safer and more convenient.



Euromap-based robot interface

Euromap 12 robot interface is a standard feature, meeting customer's need for safer connection.

UN550D1S Specification

Model		UN550D1S												
		INJECTION UNIT												
		IU2000			IU2695			IU3500			IU4800			
Screw diameter	mm	60	68	76	68	76	84	76	84	92	84	92	100	108
Theoretical shot volume	cm ³	834	1071	1338	1198	1497	1829	1678	2050	2460	2217	2659	3142	3664
Shot weight	g	767	986	1231	1103	1377	1682	1544	1886	2263	2039	2446	2890	3371
Injection pressure	Mpa	237	185	148	225	180	147	209	170	143	218	181	154	134
L/D ratio	L/D	22.6	20	20	22.3	20	20	22.1	20	20	21.9	20	21.6	20
Injection rate	cm ³ /s	322	414	517	407	508	621	463	565	678	560	671	793	925
Max. injection speed	mm/s	114			112			102			101			
Screw stroke	mm	295			330			370			400			
Max. screw speed	r/min	250			197			157			166			
Barrel heating zone	PCS	5			6			6			6			
		CLAMPING UNIT												
Clamping force	kN	5500												
Opening force	kN	390												
Platen size	mm	1270×1260												
Space between tie bars	mm	910×830												
Max. mold thickness	mm	900												
Min. mold thickness	mm	350												
Opening stroke	mm	1300/750												
Max. daylight	mm	1650												
Ejector force	kN	110												
Ejector stroke	mm	250												
Ejector number	PCS	21												
		POWER UNIT												
System pressure	MPa	17.5/30			17.5/30			17.5/30			17.5/30			
Pump motor	kW	59.6+5.5			68.5+5.5			68.5+5.5			78.5+7.5			
Total power	kW	87.5	87.5	91.2	100.6	100.6	105.1	107.4	107.4	110.6	123.1	123.1	136.5	136.5
Heating power	kW	22.4	22.4	26.1	26.6	26.6	31.1	33.4	33.4	36.6	37.1	37.1	50.5	50.5
		GENERAL												
Oil tank capacity	L	640			640			640			820			
Machine dimensions	m	7.5×2.3×2.8			7.5×2.3×2.8			7.5×2.3×2.8			8.2×2.4×2.8			
Max. mold weight	T	8			8			8			8			

- Opening force refers to mold opening force generated during high-pressure mold open.
- In the case of opening stroke, data before the slash refer to mold opening stroke with minimum mold height and opening stroke with maximum mold height.
- Mold-bearing capacity of the movable platen is 2/3 of total mold weight.
- The shot weight is calculated by GPPS and it is 0.92 times of the theoretical shot volume.
- The medium screw diameter is standard on the machine.
- The injection unit data are in international units and calculated as follows: theoretical shot volume [cm³] × injection pressure (MPa)/100
- The green figures are standard specifications of clamping unit and injection unit.
- Because of constant technical improvement, the machine specifications are subject to change without notice.

Machine Dimensions

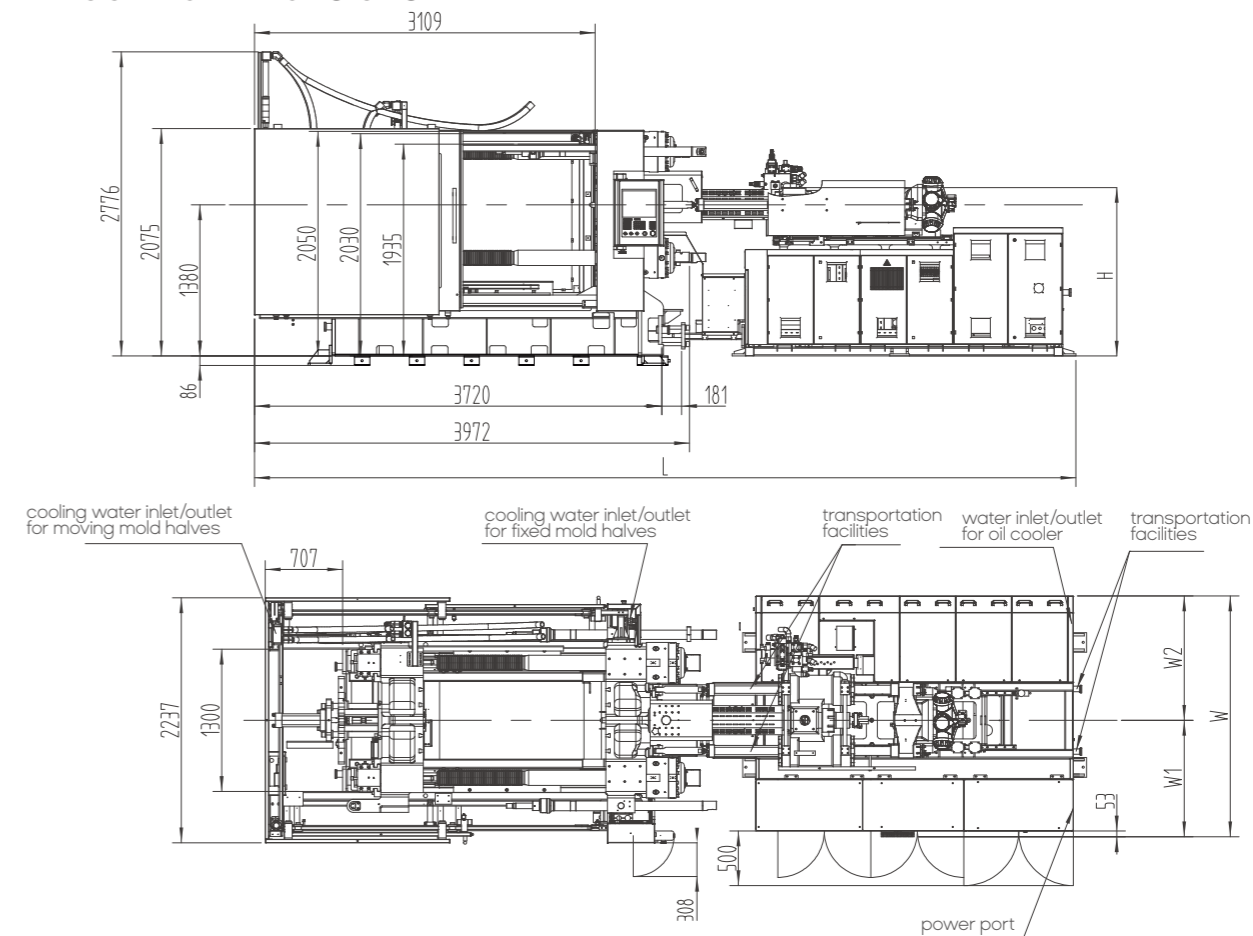

Platen Dimensions

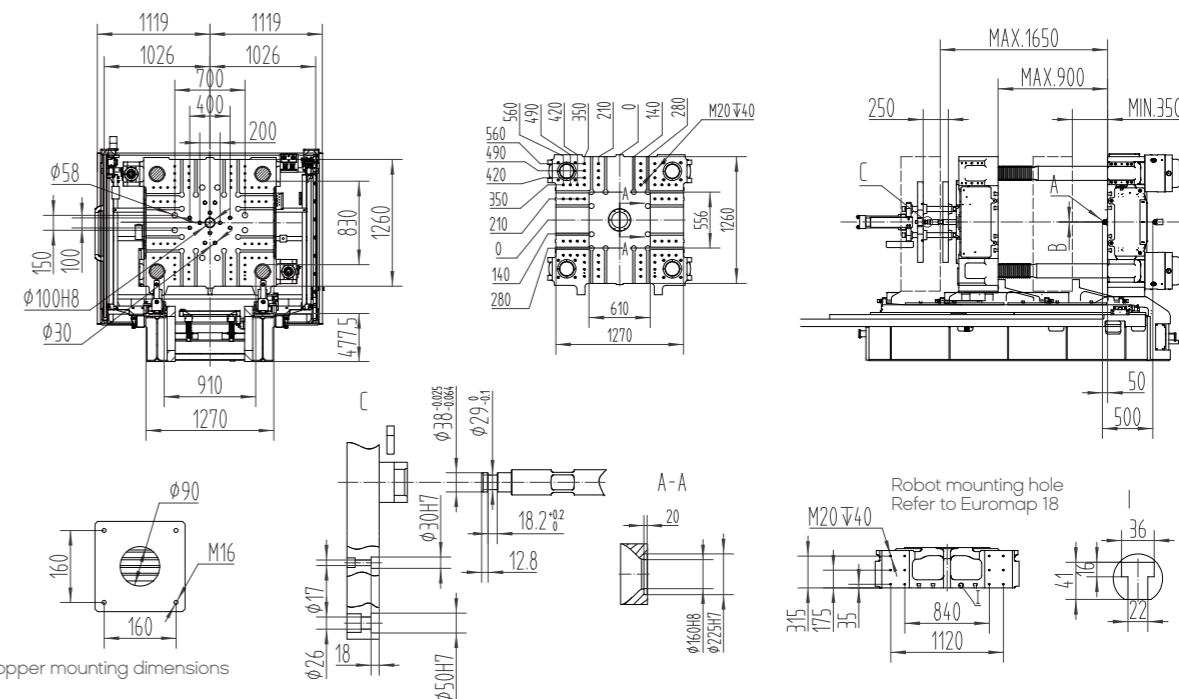

Hopper mounting dimensions

Model	A	B	L	H	W	W1	W2	Main power cord size	Full-load current	Bearing capacity of foundation	Mold cooling water ports	Cooling water flow (mold excluded)	Cooling water pressure	Compressed air pressure
	mm	mm	mm	mm	mm	mm	mm	mm ²	A	t/m ²	n×L/min	L/min	bar	bar
UN550D1S-IU2000	SR10	Ø3.5	7500	1534	2198	1063	1135	70	181.91	7.5	(8+8)×11	100	3~4	5~6
UN550D1S-IU2695	SR15	Ø4	7500	1537	2198	1063	1135	70	188.35					
UN550D1S-IU3500	SR15	Ø4	7500	1555	2198	1063	1135	70	198.61					
UN550D1S-IU4800	SR15	Ø4.5	8189.5	1565	2333	1113	1220	70	228.27					

UN750D1S Specification

Model		UN750D1S													
		INJECTION UNIT													
		IU2695			IU3500			IU4800				IU6800			
Screw diameter	mm	68	76	84	76	84	92	84	92	100	108	92	100	108	116
Theoretical shot volume	cm ³	1198	1497	1829	1678	2050	2460	2217	2659	3142	3664	3191	3770	4397	5073
Shot weight	g	1103	1377	1682	1544	1886	2263	2039	2446	2890	3371	2936	3468	4045	4667
Injection pressure	Mpa	225	180	147	209	170	143	218	181	154	134	213	180	154	134
L/D ratio	L/D	22.3	20	20	22.1	20	20	21.9	20	21.6	20	21.7	22	21.5	20
Injection rate	cm ³ /s	407	508	621	463	565	678	560	671	793	925	665	785	916	1057
Max. injection speed	mm/s	112			102			101				100			
Screw stroke	mm	330			370			400				480			
Max. screw speed	r/min	197			157			166				156			
Barrel heating zone	PCS	6			6			6				7			
		CLAMPING UNIT													
Clamping force	kN	7500													
Opening force	kN	500													
Platen size	mm	1510×1440													
Space between tie bars	mm	1100×960													
Max. mold thickness	mm	950													
Min. mold thickness	mm	450													
Opening stroke	mm	1450/950													
Max. daylight	mm	1900													
Ejector force	kN	110													
Ejector stroke	mm	250													
Ejector number	PCS	21													
		POWER UNIT													
System pressure	MPa	17.5/30			17.5/30			17.5/30				17.5/30			
Pump motor	kW	68.5+5.5			68.5+5.5			78.5+7.5				80.1+7.5			
Total power	kW	100.6	100.6	105.1	107.4	107.4	110.6	123.1	123.1	136.5	136.5	129	134.7	142.4	142.4
Heating power	kW	26.6	26.6	31.1	33.4	33.4	36.6	37.1	37.1	50.5	50.5	41.4	47.1	54.8	54.8
		GENERAL													
Oil tank capacity	L	640			640			820				970			
Machine dimensions	m	7.9×2.6×2.9			7.9×2.6×2.9			8.6×2.6×2.9				8.8×2.7×2.9			
Max. mold weight	T	11			11			11				11			

- Opening force refers to mold opening force generated during high-pressure mold open.
- In the case of opening stroke, data before the slash refer to mold opening stroke with minimum mold height and opening stroke with maximum mold height.
- Mold-bearing capacity of the movable platen is 2/3 of total mold weight.
- The shot weight is calculated by GPPS and it is 0.92 times of the theoretical shot volume.
- The medium screw diameter is standard on the machine.
- The injection unit data are in international units and calculated as follows: theoretical shot volume [cm³] × injection pressure [MPa]/100
- The green figures are standard specifications of clamping unit and injection unit.
- Because of constant technical improvement, the machine specifications are subject to change without notice.

Machine Dimensions

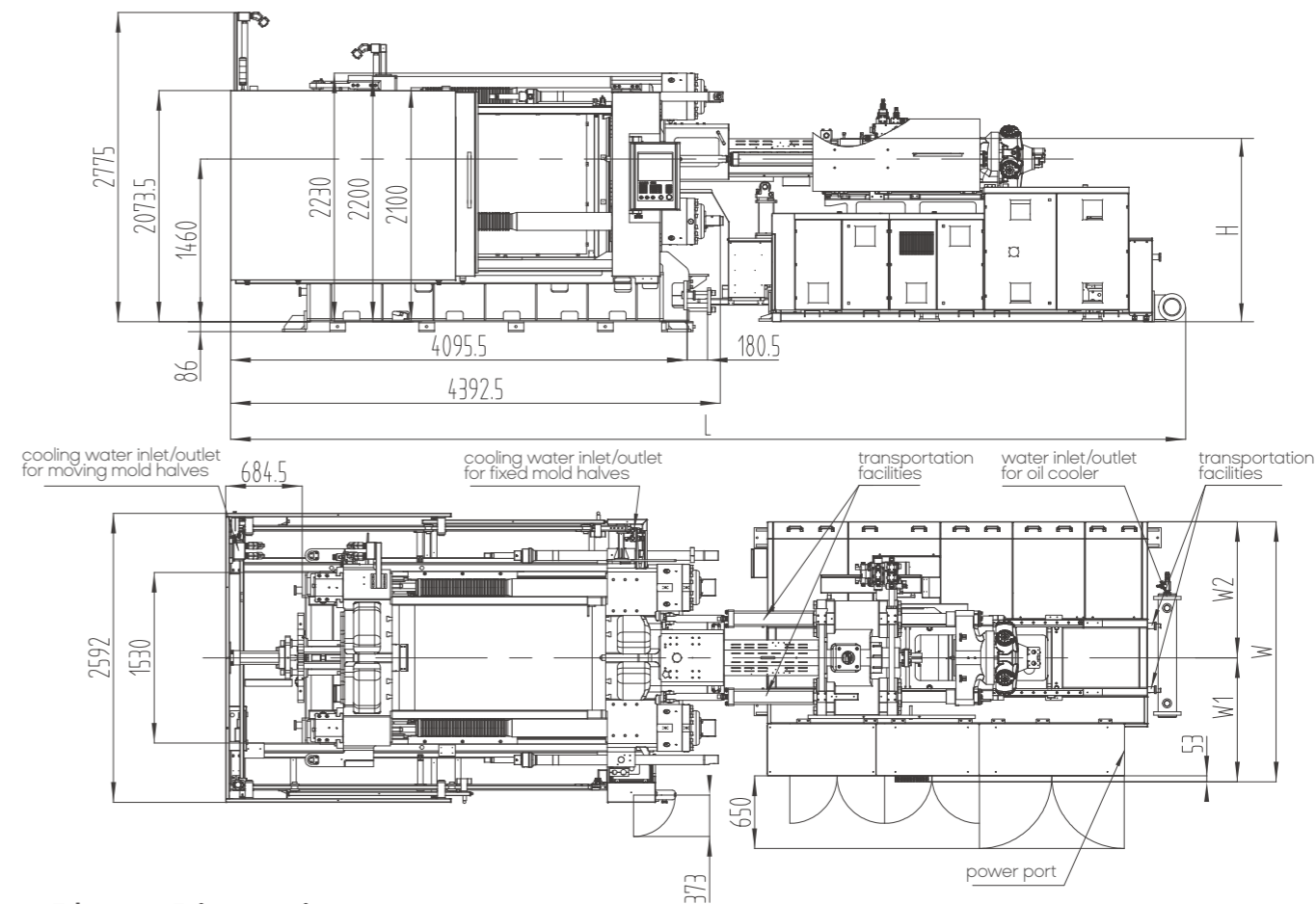

Platen Dimensions

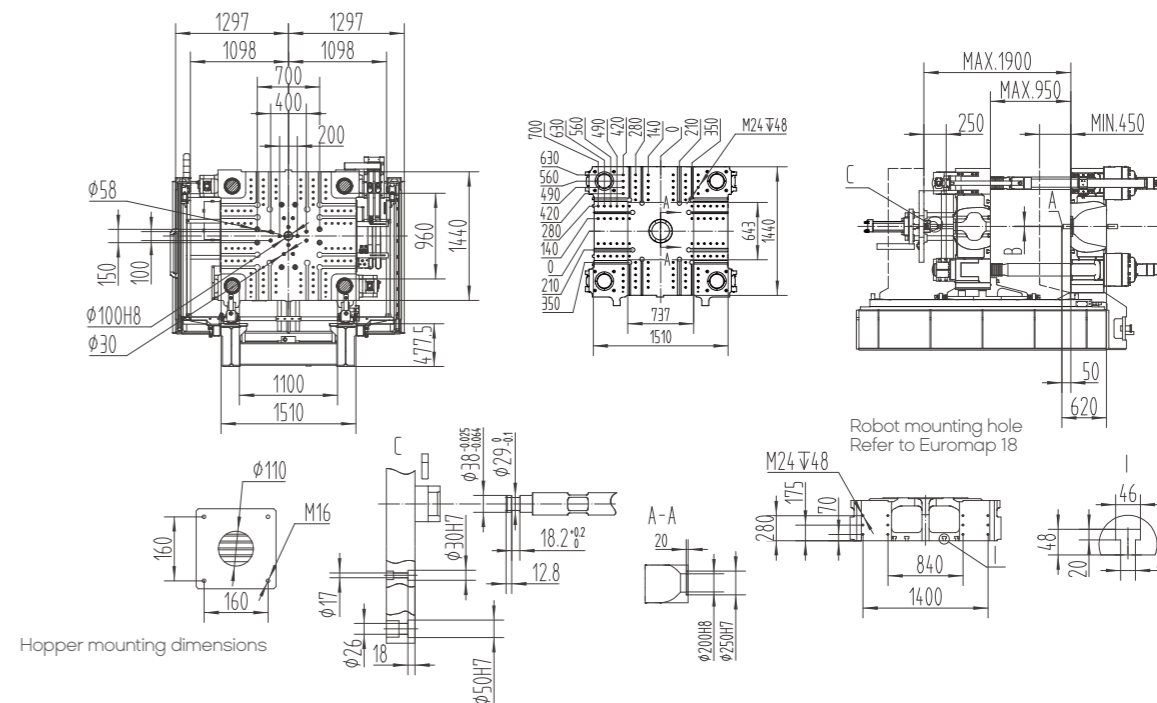

Model	A	B	L	H	W	W1	W2	Main power cord size	Full-load current	Bearing capacity of foundation	Mold cooling water ports	Cooling water flow (mold excluded)	Cooling water pressure	Compressed air pressure
	mm	mm	mm	mm	mm	mm	mm	mm ²	A	t/m ²	n×L/min	L/min	bar	bar
UN750D1S-IU2695	SR15	Ø4	7875	1617	2198	1063	1135	70	188.35	7.5	(8+8)×11	100	3~4	5~6
UN750D1S-IU3500	SR15	Ø4	7875	1635	2198	1063	1135	70	198.61					
UN750D1S-IU4800	SR15	Ø4.5	8564.5	1645	2333	1113	1220	70	228.27					
UN750D1S-IU6800	SR15	Ø4.5	8718.5	1645	2711	1352	1359	75	246.58					

UN900D1S Specification

Model		UN900D1S											
		INJECTION UNIT											
		IU4800				IU6800				IU9300			
Screw diameter	mm	84	92	100	108	92	100	108	116	100	108	116	125
Theoretical shot volume	cm ³	2217	2659	3142	3664	3191	3770	4397	5073	4320	5038	5813	6750
Shot weight	g	2039	2446	2890	3371	2936	3468	4045	4667	3974	4635	5348	6210
Injection pressure	Mpa	218	181	154	134	213	180	154	134	215	184	160	138
L/D ratio	L/D	21.9	20	21.6	20	21.7	22	21.5	20	21.6	20	21.6	20
Injection rate	cm ³ /s	560	671	793	925	665	785	916	1057	801	934	1078	1252
Max. injection speed	mm/s	101				100				102			
Screw stroke	mm	400				480				550			
Max. screw speed	r/min	166				156				128			
Barrel heating zone	PCS	6				7				7			
		CLAMPING UNIT											
Clamping force	kN	9000											
Opening force	kN	640											
Platen size	mm	1560×1520											
Space between tie bars	mm	1180×1000											
Max. mold thickness	mm	1100											
Min. mold thickness	mm	500											
Opening stroke	mm	1650/1050											
Max. daylight	mm	2150											
Ejector force	kN	220											
Ejector stroke	mm	320											
Ejector number	PCS	21											
		POWER UNIT											
System pressure	MPa	17.5/30				17.5/30				17.5/30			
Pump motor	kW	78.5+7.5				80.1+7.5				117.8+7.5			
Total power	kW	123.1	123.1	136.5	136.5	129	134.7	142.4	142.4	177.1	177.1	186.2	186.2
Heating power	kW	37.1	37.1	50.5	50.5	41.4	47.1	54.8	54.8	51.8	51.8	60.9	60.9
		GENERAL											
Oil tank capacity	L	820				970				1150			
Machine dimensions	m	9.1×3.3×2.9				9.3×3.3×2.9				9.5×3.3×2.9			
Max. mold weight	T	13				13				13			

- Opening force refers to mold opening force generated during high-pressure mold open.
- In the case of opening stroke, data before the slash refer to mold opening stroke with minimum mold height and opening stroke with maximum mold height.
- Mold-bearing capacity of the movable platen is 2/3 of total mold weight.
- The shot weight is calculated by GPPS and it is 0.92 times of the theoretical shot volume.
- The medium screw diameter is standard on the machine.
- The injection unit data are in international units and calculated as follows: theoretical shot volume [cm³] × injection pressure [MPa]/100
- The green figures are standard specifications of clamping unit and injection unit.
- Because of constant technical improvement, the machine specifications are subject to change without notice.

Machine Dimensions

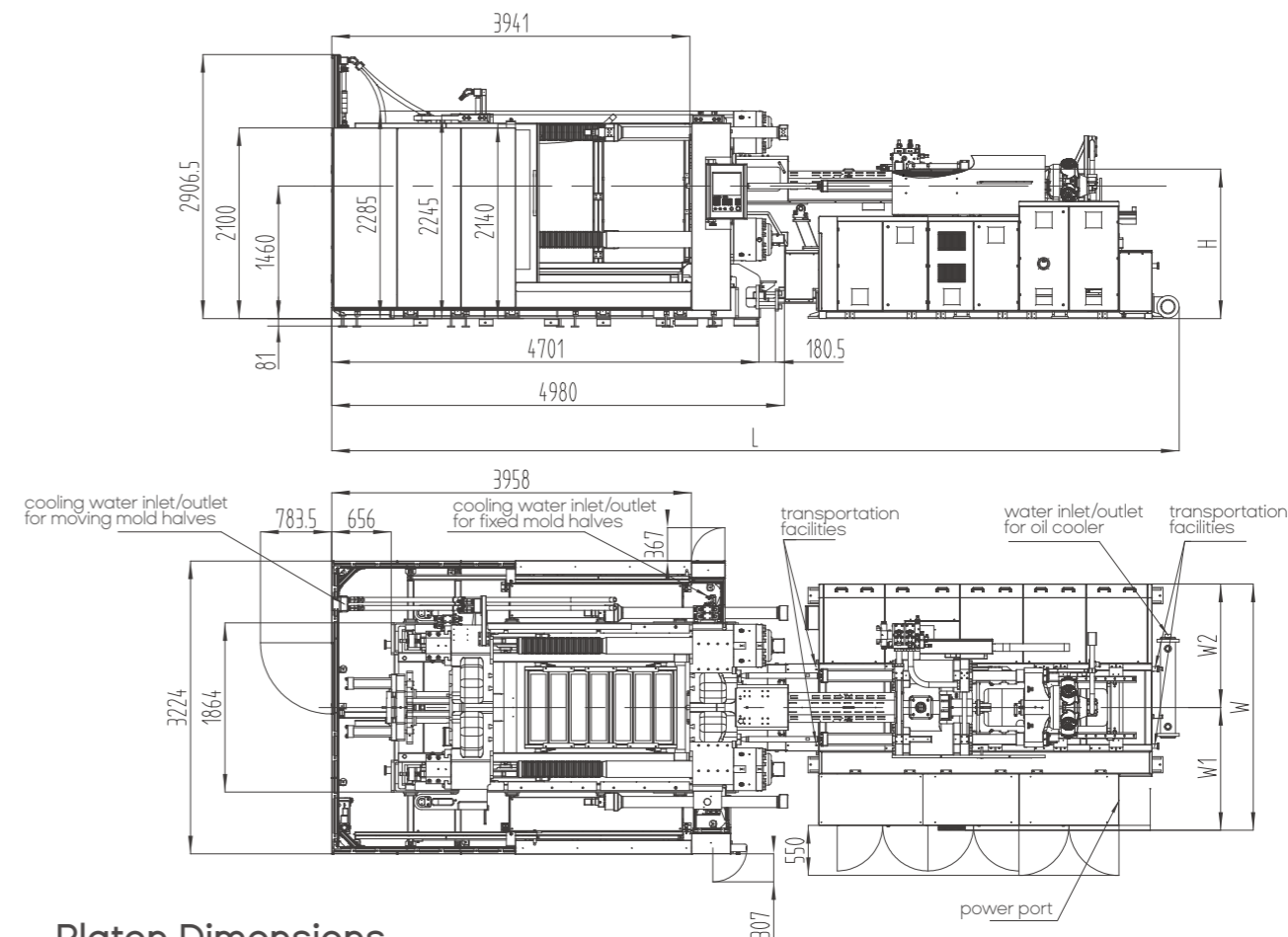

Platen Dimensions

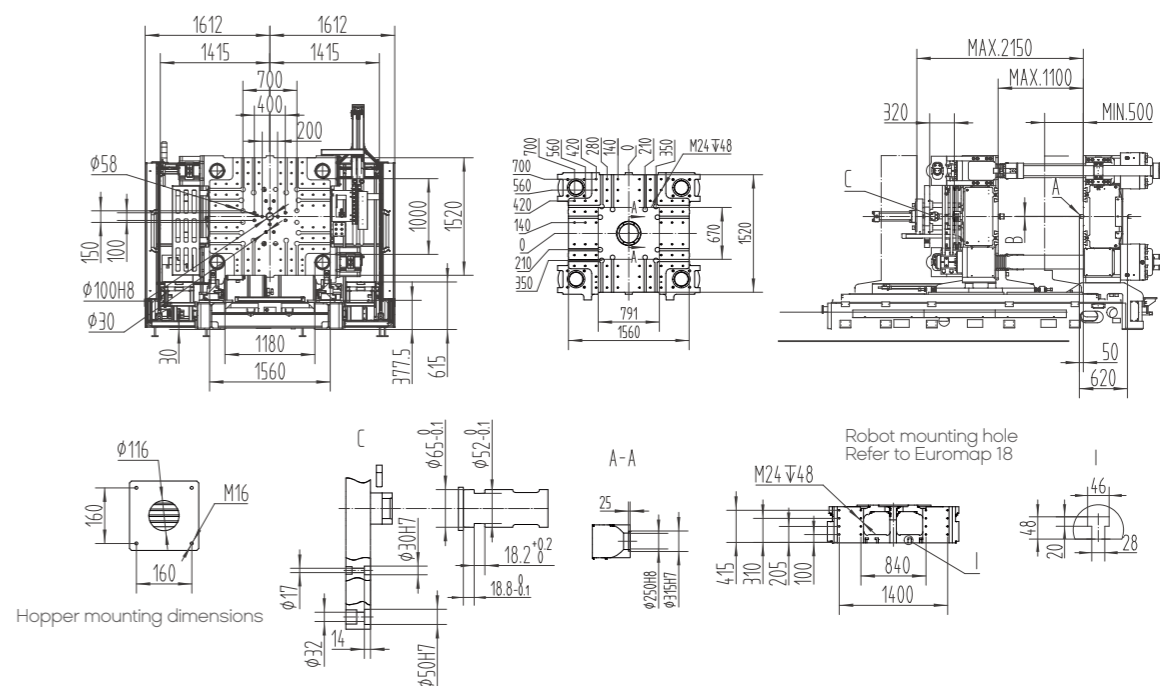

Model	A	B	L	H	W	W1	W2	Main power cord size	Full-load current	Bearing capacity of foundation	Mold cooling water ports	Cooling water flow (mold excluded)	Cooling water pressure	Compressed air pressure
	mm	mm	mm	mm	mm	mm	mm	mm ²	A	t/m ²	n×L/min	L/min	bar	bar
UN900D1S-IU4800	SR15	Ø4.5	9170	1645	2333	1113	1220	70	228.27	7.5	(8+8)×11	100	3~4	5~6
UN900D1S-IU6800	SR15	Ø4.5	9324	1645	2711	1352	1359	75	246.58					
UN900D1S-IU9300	SR15	Ø4.5	9463	1674	2756	1300.5	1455.5	95	337.02					

UN1100D1S Specification

Model		UN1100D1S															
		INJECTION UNIT															
		IU4800				IU6800				IU9300				IU11300			
Screw diameter	mm	84	92	100	108	92	100	108	116	100	108	116	125	108	116	125	135
Theoretical shot volume	cm ³	2217	2659	3142	3664	3191	3770	4397	5073	4320	5038	5813	6750	5222	6024	6995	8159
Shot weight	g	2039	2446	2890	3371	2936	3468	4045	4667	3974	4635	5348	6210	4804	5542	6435	7506
Injection pressure	Mpa	218	181	154	134	213	180	154	134	215	184	160	138	216	187	162	139
L/D ratio	L/D	21.9	20	21.6	20	21.7	22	21.5	20	21.6	20	21.6	20	22	22	21.6	20
Injection rate	cm ³ /s	560	671	793	925	665	785	916	1057	801	934	1078	1252	864	997	1157	1350
Max. injection speed	mm/s	101				100				102				94.3			
Screw stroke	mm	400				480				550				570			
Max. screw speed	r/min	166				156				128				112			
Barrel heating zone	PCS	6				7				7				8			
		CLAMPING UNIT															
Clamping force	kN	11000															
Opening force	kN	760															
Platen size	mm	1700×1660															
Space between tie bars	mm	1270×1100															
Max. mold thickness	mm	1200															
Min. mold thickness	mm	600															
Opening stroke	mm	1800/1200															
Max. daylight	mm	2400															
Ejector force	kN	274															
Ejector stroke	mm	360															
Ejector number	PCS	25															
		POWER UNIT															
System pressure	MPa	17.5/30				17.5/30				17.5/30				17.5/30			
Pump motor	kW	78.5+7.5				80.1+7.5				117.8+7.5				80.1+35.6+7.5			
Total power	kW	123.1	123.1	136.5	136.5	129	134.7	142.4	142.4	177.1	177.1	186.2	186.2	189.6	189.6	189.6	193.8
Heating power	kW	37.1	37.1	50.5	50.5	41.4	47.1	54.8	54.8	51.8	51.8	60.9	60.9	66.4	66.4	66.4	70.6
		GENERAL															
Oil tank capacity	L	820				970				1150				1270			
Machine dimensions	m	9.6×3.3×3.1				9.8×3.3×3.1				9.9×3.3×3.1				10.5×3.3×3.1			
Max. mold weight	T	16				16				16				16			

- Opening force refers to mold opening force generated during high-pressure mold open.
- In the case of opening stroke, data before the slash refer to mold opening stroke with minimum mold height and opening stroke with maximum mold height.
- Mold-bearing capacity of the movable platen is 2/3 of total mold weight.
- The shot weight is calculated by GPPS and it is 0.92 times of the theoretical shot volume.
- The medium screw diameter is standard on the machine.
- The injection unit data are in international units and calculated as follows: theoretical shot volume [cm³] × injection pressure [MPa]/100
- The green figures are standard specifications of clamping unit and injection unit.
- Because of constant technical improvement, the machine specifications are subject to change without notice.

Machine Dimensions

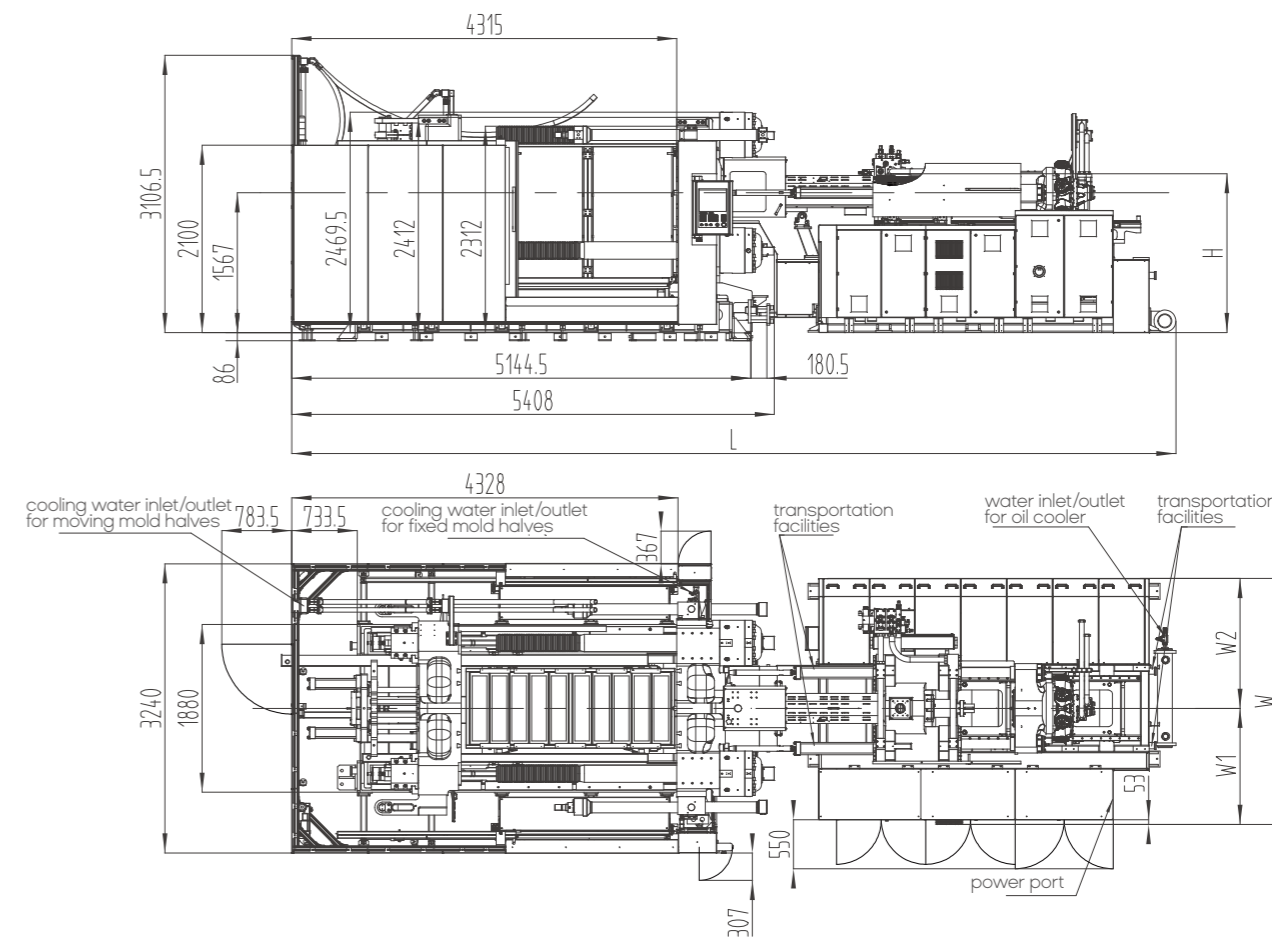

Platen Dimensions

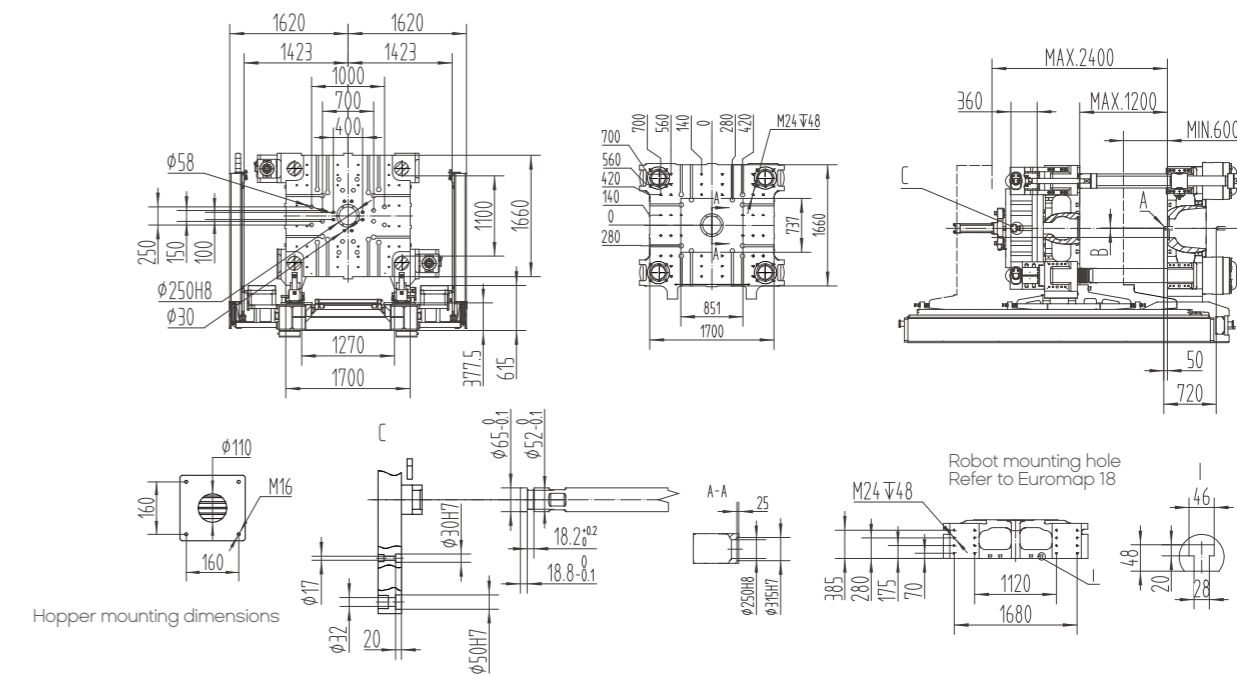

Model	A	B	L	H	W	W1	W2	Main power cord size	Full-load current	Bearing capacity of foundation	Mold cooling water ports	Cooling water flow (mold excluded)	Cooling water pressure	Compressed air pressure
	mm	mm	mm	mm	mm	mm	mm	mm ²	A	t/m ²	n×L/min	L/min	bar	bar
UN1100D1S-IU4800	SR15	Ø4.5	9613.5	1752	2333	1113	1220	70	228.27	8	(8+8)×11	100	3~4	5~6
UN1100D1S-IU6800	SR15	Ø4.5	9767.5	1752	2711	1352	1359	75	246.58					
UN1100D1S-IU9300	SR15	Ø4.5	9906.5	1781	2756	1300.5	1455.5	95	337.02					
UN1100D1S-IU11300	SR20	Ø6	10533.5	1801	2906	1450.5	1455.5	120	354.96					

UN1200D1S Specification

Model		UN1200D1S															
		INJECTION UNIT															
		IU4800				IU6800				IU9300				IU11300			
Screw diameter	mm	84	92	100	108	92	100	108	116	100	108	116	125	108	116	125	135
Theoretical shot volume	cm ³	2217	2659	3142	3664	3191	3770	4397	5073	4320	5038	5813	6750	5222	6024	6995	8159
Shot weight	g	2039	2446	2890	3371	2936	3468	4045	4667	3974	4635	5348	6210	4804	5542	6435	7506
Injection pressure	Mpa	218	181	154	134	213	180	154	134	215	184	160	138	216	187	162	139
L/D ratio	L/D	21.9	20	21.6	20	21.7	22	21.5	20	21.6	20	21.6	20	22	22	21.6	20
Injection rate	cm ³ /s	560	671	793	925	665	785	916	1057	801	934	1078	1252	864	997	1157	1350
Max. injection speed	mm/s	101				100				102				94.3			
Screw stroke	mm	400				480				550				570			
Max. screw speed	r/min	166				156				128				112			
Barrel heating zone	PCS	6				7				7				8			
		CLAMPING UNIT															
Clamping force	kN	12000															
Opening force	kN	875															
Platen size	mm	1860×1760															
Space between tie bars	mm	1310×1200															
Max. mold thickness	mm	1250															
Min. mold thickness	mm	600															
Opening stroke	mm	2050/1400															
Max. daylight	mm	2650															
Ejector force	kN	274															
Ejector stroke	mm	360															
Ejector number	PCS	25															
		POWER UNIT															
System pressure	MPa	17.5/30				17.5/30				17.5/30				17.5/30			
Pump motor	kW	78.5+7.5				80.1+7.5				117.8+7.5				80.1+35.6+7.5			
Total power	kW	123.1	123.1	136.5	136.5	129	134.7	142.4	142.4	177.1	177.1	186.2	186.2	189.6	189.6	189.6	193.8
Heating power	kW	37.1	37.1	50.5	50.5	41.4	47.1	54.8	54.8	51.8	51.8	60.9	60.9	66.4	66.4	66.4	70.6
		GENERAL															
Oil tank capacity	L	820				970				1150				1270			
Machine dimensions	m	10.1×3.4×3.1				10.3×3.4×3.1				10.4×3.4×3.1				11×3.4×3.1			
Max. mold weight	T	20				20				20				20			

1. Opening force refers to mold opening force generated during high-pressure mold open.
 2. In the case of opening stroke, data before the slash refer to mold opening stroke with minimum mold height and opening stroke with maximum mold height.
 3. Mold-bearing capacity of the movable platen is 2/3 of total mold weight.
 4. The shot weight is calculated by GPPS and it is 0.92 times of the theoretical shot volume.
 5. The medium screw diameter is standard on the machine.
 6. The injection unit data are in international units and calculated as follows: theoretical shot volume [cm³] × injection pressure [MPa]/100
 7. The green figures are standard specifications of clamping unit and injection unit.
 8. Because of constant technical improvement, the machine specifications are subject to change without notice.

Machine Dimensions

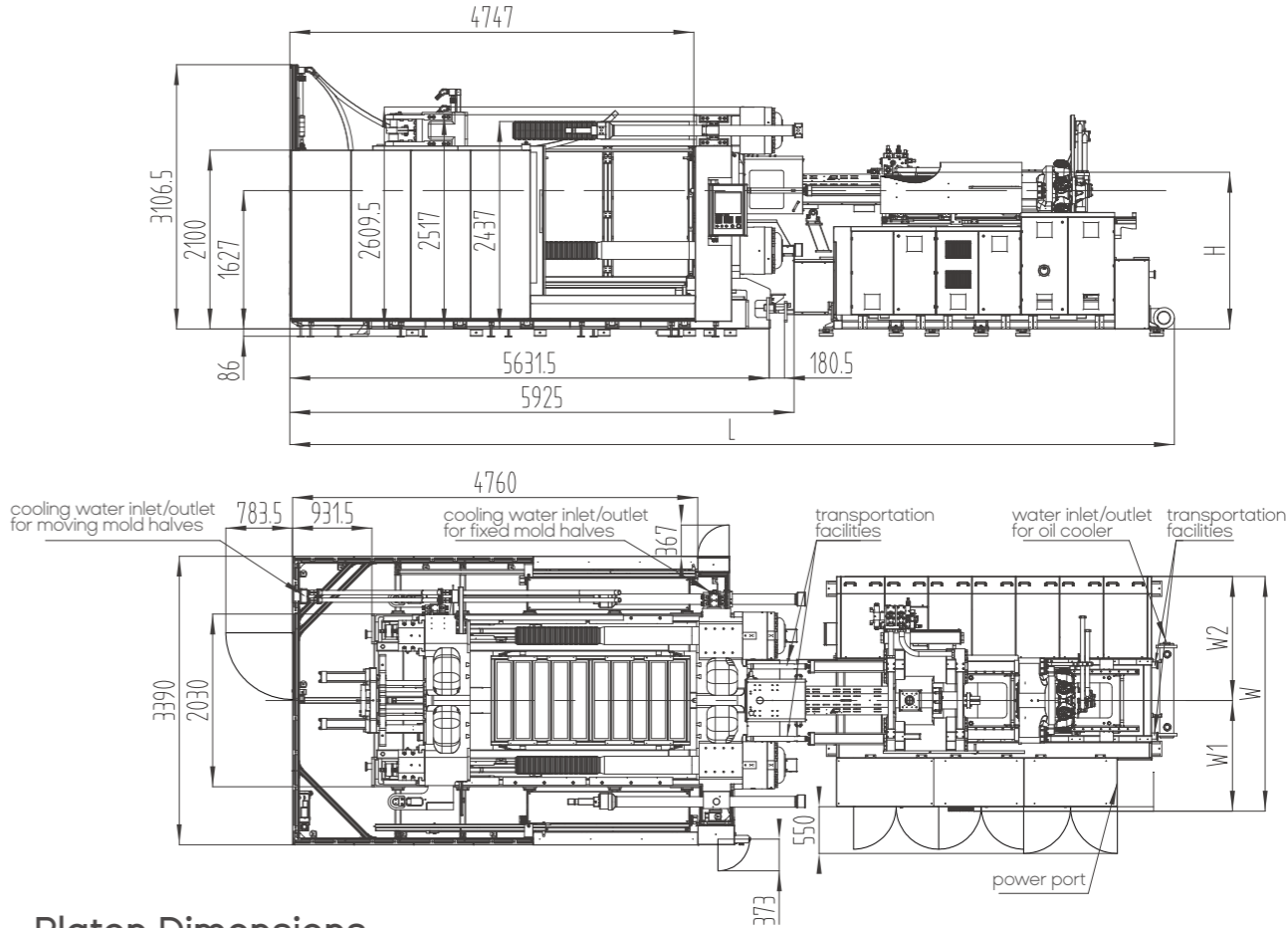

Platen Dimensions

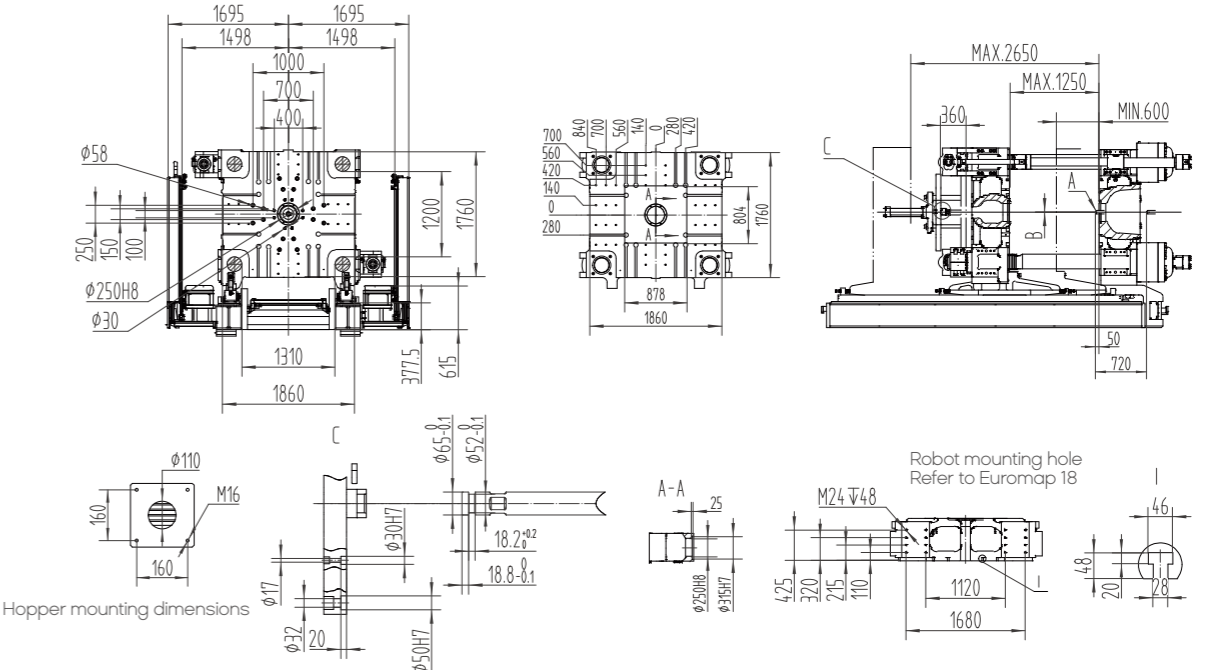

Model	A	B	L	H	W	W1	W2	Main power cord size	Full-load current	Bearing capacity of foundation	Mold cooling water ports	Cooling water flow (mold excluded)	Cooling water pressure	Compressed air pressure
	mm	mm	mm	mm	mm	mm	mm	mm ²	A	t/m ²	n×L/min	L/min	bar	bar
UN1200D1S-IU4800	SR15	Ø4.5	10100.5	1812	2333	1113	1220	70	228.27	8	(8+8)×11	100	3~4	5~6
UN1200D1S-IU6800	SR15	Ø4.5	10254.5	1812	2711	1352	1359	75	246.58					
UN1200D1S-IU9300	SR15	Ø4.5	10393.5	1841	2756	1300.5	1455.5	95	337.02					
UN1200D1S-IU11300	SR20	Ø6	11020.5	1861	2906	1450.5	1455.5	120	354.96					

UN1300D1S Specification

Model		UN1300D1S															
		INJECTION UNIT															
		IU6800				IU9300				IU11300				IU16000			
Screw diameter	mm	92	100	108	116	100	108	116	125	108	116	125	135	125	135	145	
Theoretical shot volume	cm ³	3191	3770	4397	5073	4320	5038	5813	6750	5222	6024	6995	8159	7977	9304	10733	
Shot weight	g	2936	3468	4045	4667	3974	4635	5348	6210	4804	5542	6435	7506	7339	8560	9875	
Injection pressure	Mpa	213	180	154	134	215	184	160	138	216	187	162	139	199	172	149	
L/D ratio	L/D	21.7	22	21.5	20	21.6	20	21.6	20	22	22	21.6	20	23.6	22	20	
Injection rate	cm ³ /s	665	785	916	1057	801	934	1078	1252	864	997	1157	1350	1313	1532	1767	
Max. injection speed	mm/s	100				102				94.3				107			
Screw stroke	mm	480				550				570				650			
Max. screw speed	r/min	156				128				112				120			
Barrel heating zone	PCS	7				7				8				8			
		CLAMPING UNIT															
Clamping force	kN	13000															
Opening force	kN	875															
Platen size	mm	1975×1875															
Space between tie bars	mm	1390×1280															
Max. mold thickness	mm	1350															
Min. mold thickness	mm	650															
Opening stroke	mm	2200/1500															
Max. daylight	mm	2850															
Ejector force	kN	274															
Ejector stroke	mm	360															
Ejector number	PCS	25															
		POWER UNIT															
System pressure	MPa	17.5/30				17.5/30				17.5/30				17.5/30			
Pump motor	kW	80.1+7.5				117.8+7.5				80.1+35.6+7.5				89.5+78.5+11			
Total power	kW	129	134.7	142.4	142.4	177.1	177.1	186.2	186.2	189.6	189.6	189.6	193.8	256.7			
Heating power	kW	41.4	47.1	54.8	54.8	51.8	51.8	60.9	60.9	66.4	66.4	66.4	70.6	87.7			
		GENERAL															
Oil tank capacity	L	970				1150				1270				1600			
Machine dimensions	m	10.4×3.5×3.3				10.5×3.5×3.3				11.2×3.5×3.3				11.7×3.5×3.3			
Max. mold weight	T	23				23				23				23			

- Opening force refers to mold opening force generated during high-pressure mold open.
- In the case of opening stroke, data before the slash refer to mold opening stroke with minimum mold height and opening stroke with maximum mold height.
- Mold-bearing capacity of the movable platen is 2/3 of total mold weight.
- The shot weight is calculated by GPPS and it is 0.92 times of the theoretical shot volume.
- The medium screw diameter is standard on the machine.
- The injection unit data are in international units and calculated as follows: theoretical shot volume [cm³] × injection pressure [MPa]/100
- The green figures are standard specifications of clamping unit and injection unit.
- Because of constant technical improvement, the machine specifications are subject to change without notice.

Machine Dimensions

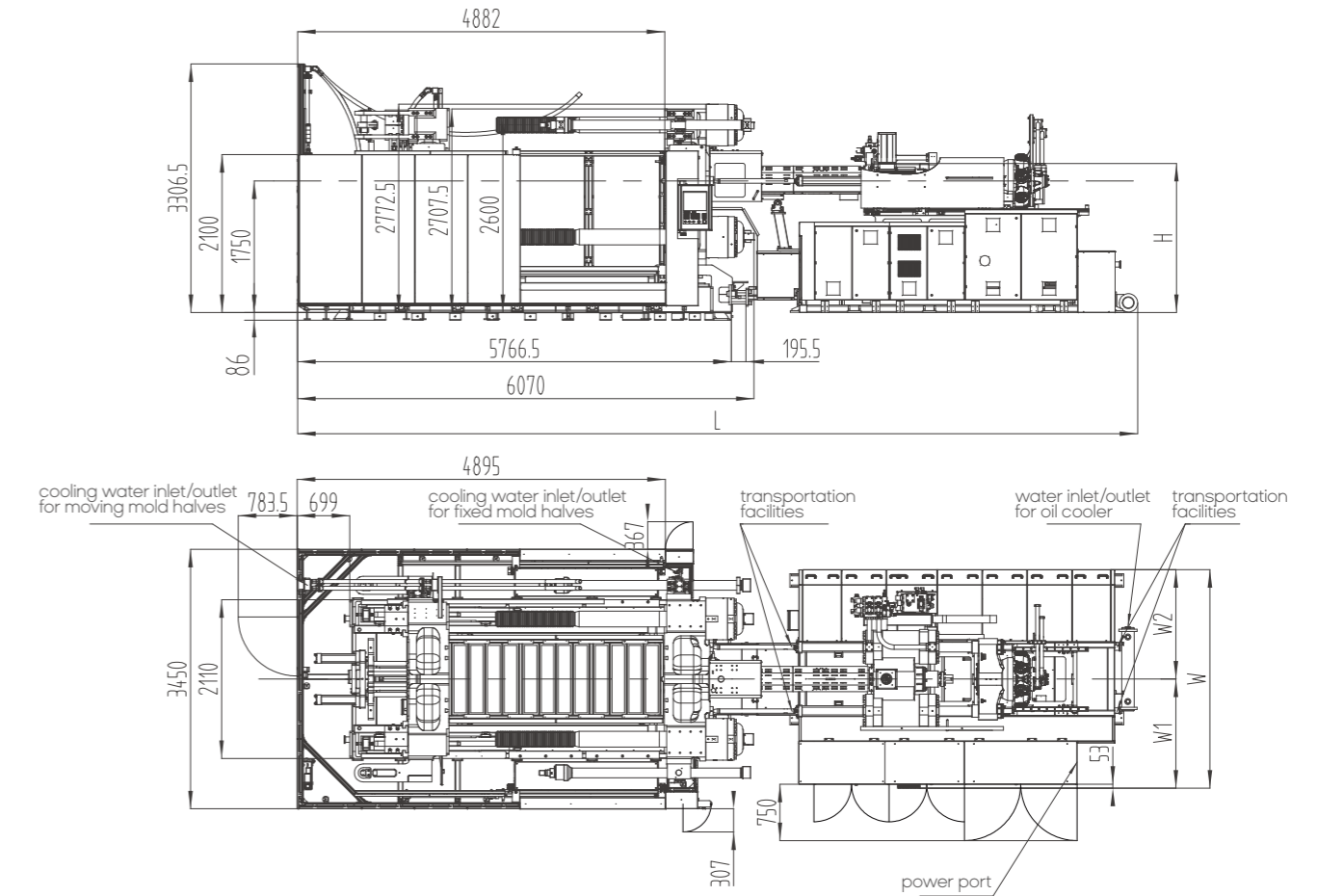

Platen Dimensions

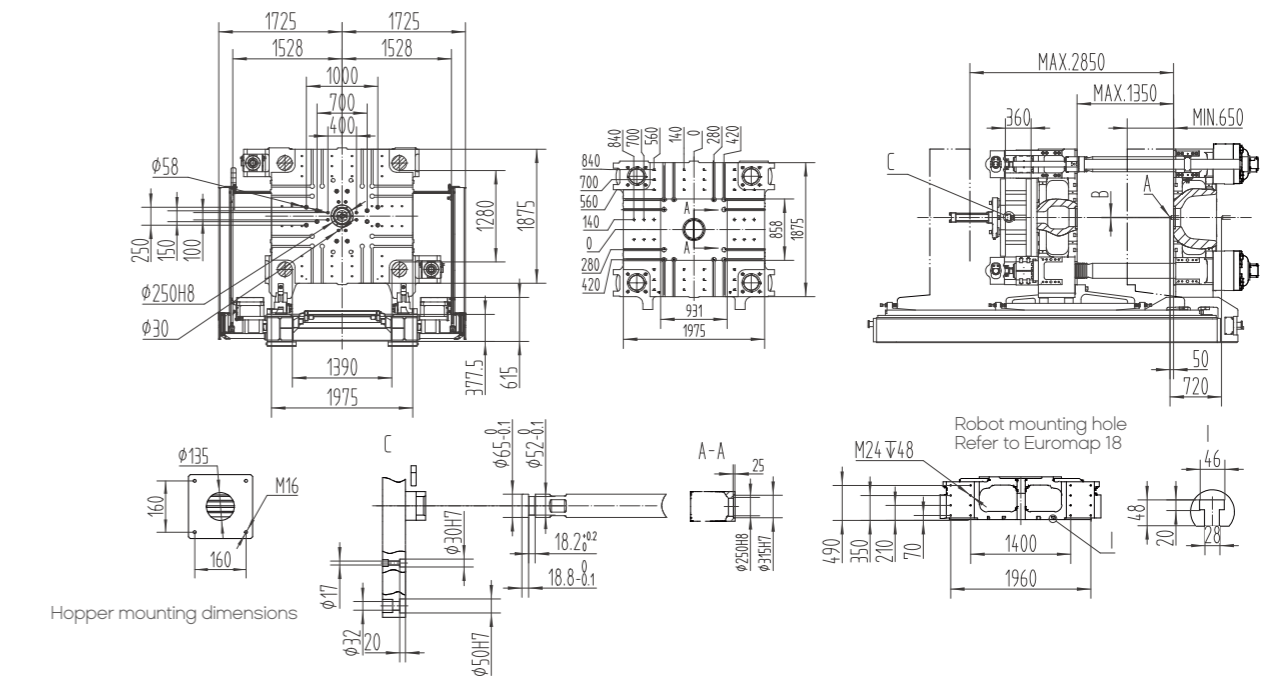

Model	A	B	L	H	W	W1	W2	Main power cord size	Full-load current	Bearing capacity of foundation	Mold cooling water ports	Cooling water flow (mold excluded)	Cooling water pressure	Compressed air pressure
	mm	mm	mm	mm	mm	mm	mm	mm ²	A	t/m ²	n×L/min	L/min	bar	bar
UN1300D1S-IU6800	SR15	Ø4.5	10404.5	1935	2711	1352	1359	75	246.58	8	(8+8)×11	100	3~4	5~6
UN1300D1S-IU9300	SR15	Ø4.5	10543.5	1964	2756	1300.5	1455.5	95	337.02					
UN1300D1S-IU11300	SR20	Ø6	11170.5	1984	2906	1450.5	1455.5	120	354.96					
UN1300D1S-IU16000	SR20	Ø8	11797.5	2008	3146	1548	1598	150	498.85					

UN1400D1S Specification

Model		UN1400D1S															
		INJECTION UNIT															
		IU6800				IU9300				IU11300				IU16000			
Screw diameter	mm	92	100	108	116	100	108	116	125	108	116	125	135	125	135	145	
Theoretical shot volume	cm ³	3191	3770	4397	5073	4320	5038	5813	6750	5222	6024	6995	8159	7977	9304	10733	
Shot weight	g	2936	3468	4045	4667	3974	4635	5348	6210	4804	5542	6435	7506	7339	8560	9875	
Injection pressure	Mpa	213	180	154	134	215	184	160	138	216	187	162	139	199	172	149	
L/D ratio	L/D	21.7	22	21.5	20	21.6	20	21.6	20	22	22	21.6	20	23.6	22	20	
Injection rate	cm ³ /s	665	785	916	1057	801	934	1078	1252	864	997	1157	1350	1313	1532	1767	
Max. injection speed	mm/s	100				102				94.3				107			
Screw stroke	mm	480				550				570				650			
Max. screw speed	r/min	156				128				112				120			
Barrel heating zone	PCS	7				7				8				8			
		CLAMPING UNIT															
Clamping force	kN	14000															
Opening force	kN	950															
Platen size	mm	2072×1975															
Space between tie bars	mm	1470×1360															
Max. mold thickness	mm	1450															
Min. mold thickness	mm	700															
Opening stroke	mm	2350/1600															
Max. daylight	mm	2850															
Ejector force	kN	300															
Ejector stroke	mm	400															
Ejector number	PCS	25															
		POWER UNIT															
System pressure	MPa	17.5/30				17.5/30				17.5/30				17.5/30			
Pump motor	kW	80.1+7.5				117.8+7.5				80.1+35.6+7.5				89.5+78.5+11			
Total power	kW	129	134.7	142.4	142.4	177.1	177.1	186.2	186.2	189.6	189.6	189.6	193.8	256.7			
Heating power	kW	41.4	47.1	54.8	54.8	51.8	51.8	60.9	60.9	66.4	66.4	66.4	70.6	87.7			
		GENERAL															
Oil tank capacity	L	970				1150				1270				1600			
Machine dimensions	m	10.7×3.6×3.3				10.8×3.6×3.3				11.5×3.6×3.3				12×3.6×3.3			
Max. mold weight	T	27				27				27				27			

- Opening force refers to mold opening force generated during high-pressure mold open.
- In the case of opening stroke, data before the slash refer to mold opening stroke with minimum mold height and opening stroke with maximum mold height.
- Mold-bearing capacity of the movable platen is 2/3 of total mold weight.
- The shot weight is calculated by GPPS and it is 0.92 times of the theoretical shot volume.
- The medium screw diameter is standard on the machine.
- The injection unit data are in international units and calculated as follows: theoretical shot volume [cm³] × injection pressure [MPa]/100
- The green figures are standard specifications of clamping unit and injection unit.
- Because of constant technical improvement, the machine specifications are subject to change without notice.

Machine Dimensions

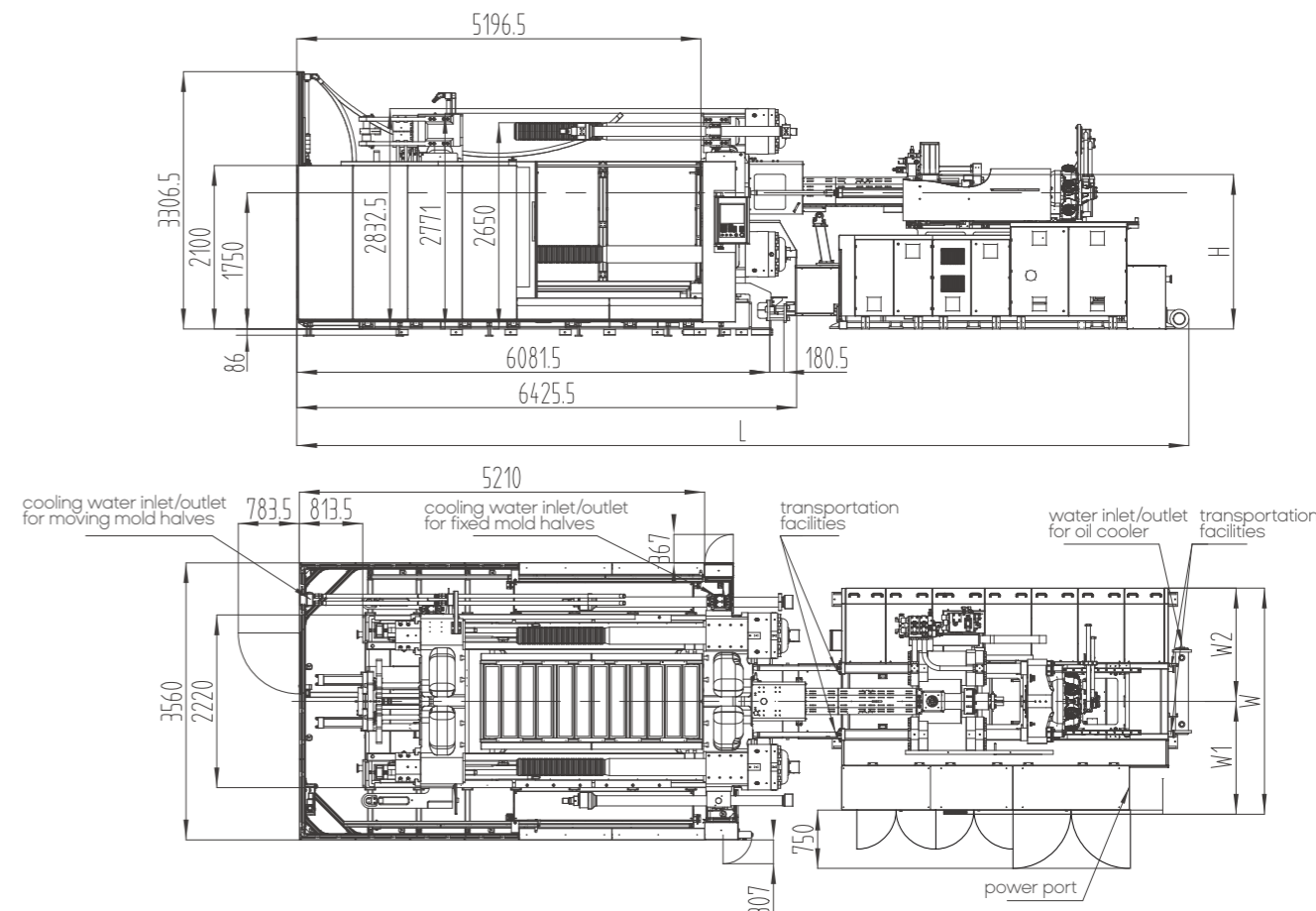

Platen Dimensions

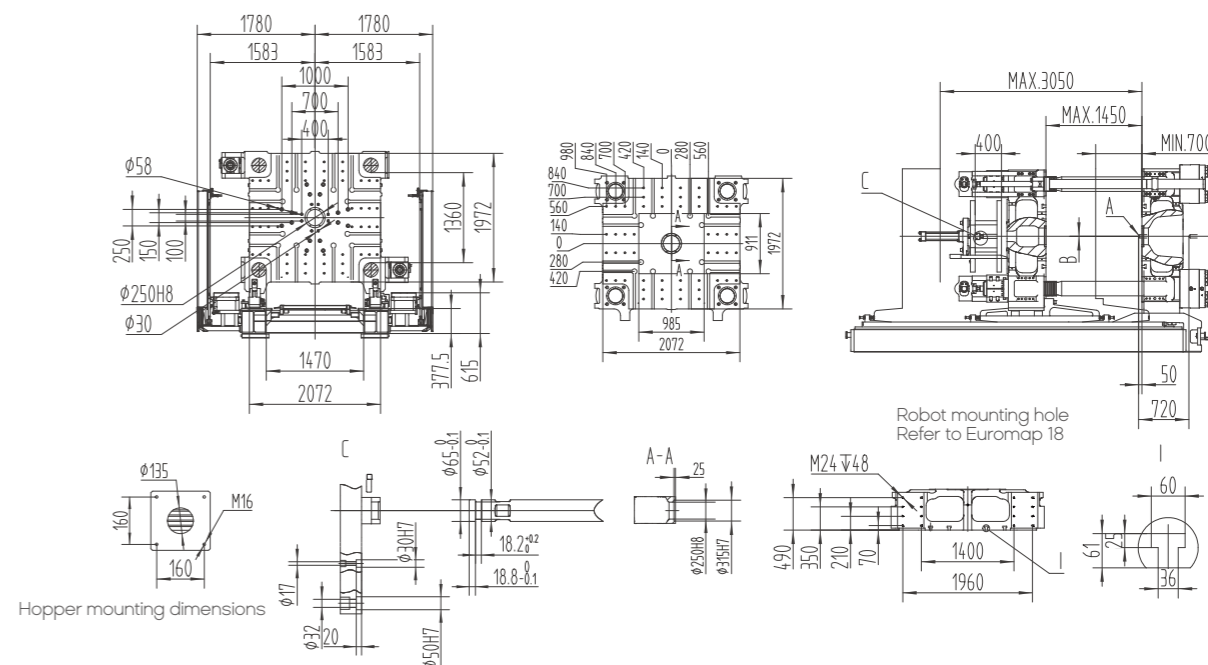

Model	A	B	L	H	W	W1	W2	Main power cord size	Full-load current	Bearing capacity of foundation	Mold cooling water ports	Cooling water flow (mold excluded)	Cooling water pressure	Compressed air pressure
	mm	mm	mm	mm	mm	mm	mm	mm ²	A	t/m ²	n×L/min	L/min	bar	bar
UN1400D1S-IU6800	SR15	Ø4.5	10704.5	1935	2711	1352	1359	75	246.58	8	(8+8)×11	100	3~4	5~6
UN1400D1S-IU9300	SR15	Ø4.5	10843.5	1964	2756	1300.5	1455.5	95	337.02					
UN1400D1S-IU11300	SR20	Ø6	11470.5	1984	2906	1450.5	1455.5	120	354.96					
UN1400D1S-IU16000	SR20	Ø8	12097.5	2008	3146	1548	1598	150	498.85			250		

UN1600D1S Specification

Model		UN1600D1S														
		INJECTION UNIT														
		IU9300				IU11300				IU16000			IU20000			
Screw diameter	mm	100	108	116	125	108	116	125	135	125	135	145	135	145	155	165
Theoretical shot volume	cm ³	4320	5038	5813	6750	5222	6024	6995	8159	7977	9304	10733	10020	11559	13208	14968
Shot weight	g	3974	4635	5348	6210	4804	5542	6435	7506	7339	8560	9875	9218	10634	12152	13770
Injection pressure	Mpa	215	184	160	138	216	187	162	139	199	172	149	199	173	151	133
L/D ratio	L/D	21.6	20	21.6	20	22	22	21.6	20	23.6	22	20	23.6	22	22	20
Injection rate	cm ³ /s	801	934	1078	1252	864	997	1157	1350	1313	1532	1767	1368	1579	1804	2044
Max. injection speed	mm/s	102				94.3				107			95.6			
Screw stroke	mm	550				570				650			700			
Max. screw speed	r/min	128				112				120			120			
Barrel heating zone	PCS	7				8				8			8			
		CLAMPING UNIT														
Clamping force	kN	16000														
Opening force	kN	1100														
Platen size	mm	2200×2100														
Space between tie bars	mm	1550×1450														
Max. mold thickness	mm	1550														
Min. mold thickness	mm	700														
Opening stroke	mm	2600/1750														
Max. daylight	mm	3300														
Ejector force	kN	300														
Ejector stroke	mm	400														
Ejector number	PCS	25														
		POWER UNIT														
System pressure	MPa	17.5/30				17.5/30				17.5/30			17.5/30			
Pump motor	kW	117.8+7.5				80.1+35.6+7.5				89.5+78.5+11			89.5+78.5+11			
Total power	kW	177.1	177.1	186.2	186.2	189.6	189.6	189.6	193.8	256.7	276.8	276.8	276.8	291.1		
Heating power	kW	51.8	51.8	60.9	60.9	66.4	66.4	66.4	70.6	87.7	97.8	97.8	97.8	112.1		
		GENERAL														
Oil tank capacity	L	1150				1270				1600			1600			
Machine dimensions	m	11.2×3.7×3.5				11.8×3.7×3.5				12.5×3.7×3.5			12.5×3.7×3.5			
Max. mold weight	T	34				34				34			34			

1. Opening force refers to mold opening force generated during high-pressure mold open.
 2. In the case of opening stroke, data before the slash refer to mold opening stroke with minimum mold height and opening stroke with maximum mold height.
 3. Mold-bearing capacity of the movable platen is 2/3 of total mold weight.
 4. The shot weight is calculated by GPPS and it is 0.92 times of the theoretical shot volume.
 5. The medium screw diameter is standard on the machine.
 6. The injection unit data are in international units and calculated as follows: theoretical shot volume [cm³] × injection pressure (MPa)/100
 7. The green figures are standard specifications of clamping unit and injection unit.
 8. Because of constant technical improvement, the machine specifications are subject to change without notice.

Machine Dimensions

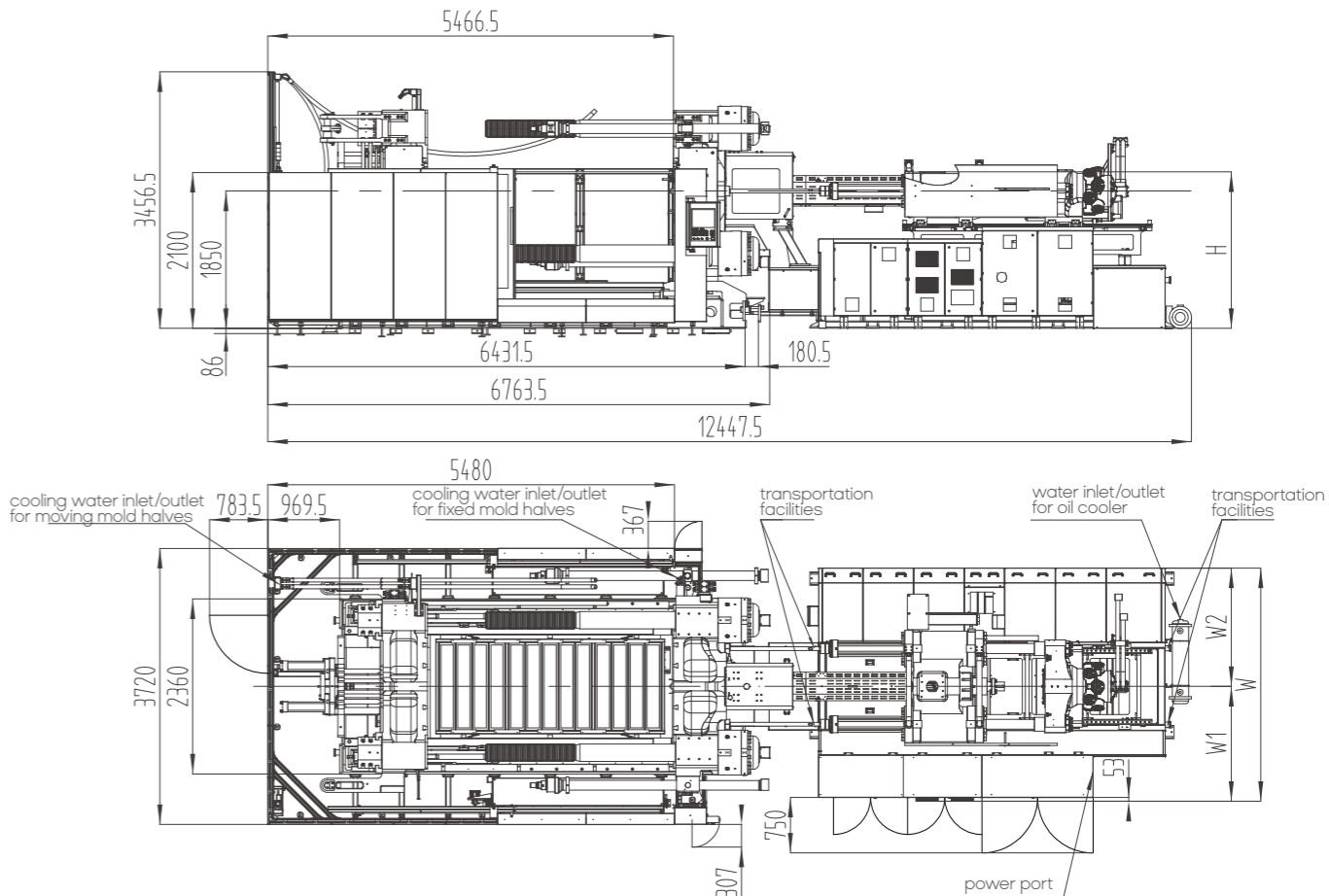

Platen Dimensions

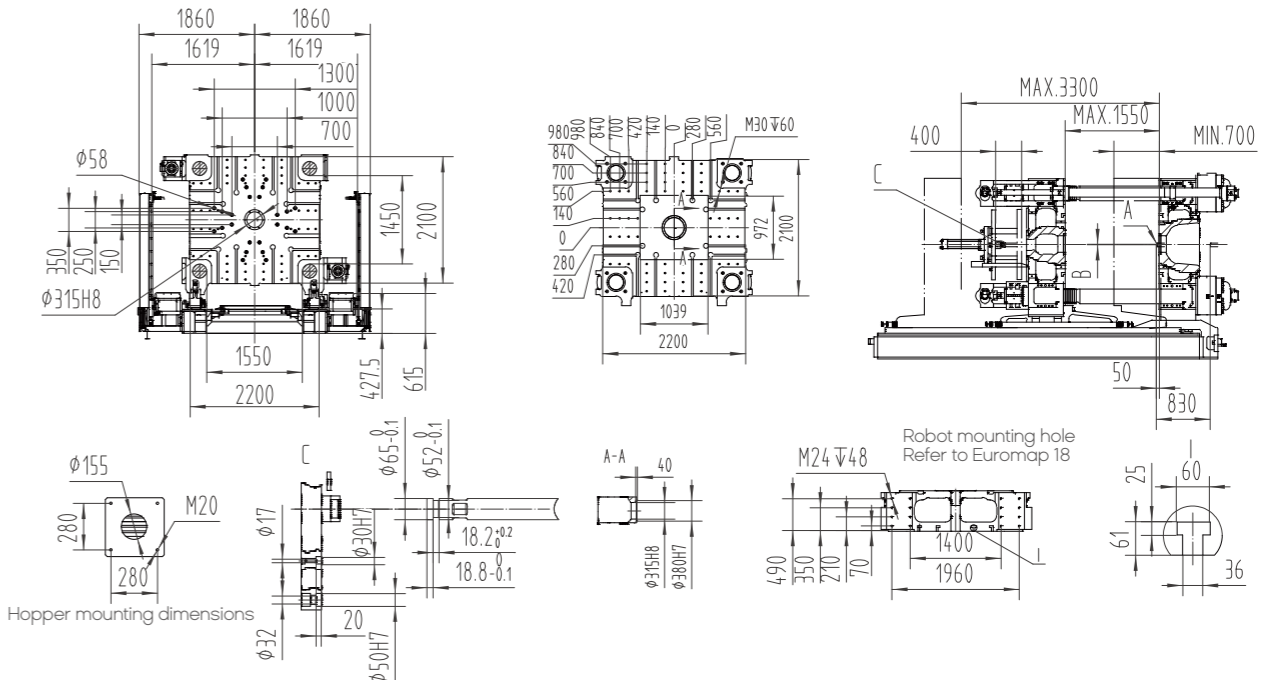

Model	A	B	L	H	W	W1	W2	Main power cord size	Full-load current	Bearing capacity of foundation	Mold cooling water ports	Cooling water flow (mold excluded)	Cooling water pressure	Compressed air pressure
	mm	mm	mm	mm	mm	mm	mm	mm ²	A	t/m ²	n×L/min	L/min	bar	bar
UN1600D1S-IU9300	SR15	Ø4.5	11193.5	2064	2756	1300.5	1455.5	95	337.02	10.5	(8+8)×11	100	3~4	5~6
UN1600D1S-IU11300	SR20	Ø6	11820.5	2084	2906	1450.5	1455.5	120	354.96					
UN1600D1S-IU16000	SR20	Ø8	12447.5	2108	3146	1548	1598	150	498.85					
UN1600D1S-IU20000	SR20	Ø8	12447.5	2123	3146	1548	1598	150	514.15					

UN1850D1S Specification

Model		UN1850D1S															
		INJECTION UNIT															
		IU9300				IU11300				IU16000				IU20000			
Screw diameter	mm	100	108	116	125	108	116	125	135	125	135	145	135	145	155	165	
Theoretical shot volume	cm ³	4320	5038	5813	6750	5222	6024	6995	8159	7977	9304	10733	10020	11559	13208	14968	
Shot weight	g	3974	4635	5348	6210	4804	5542	6435	7506	7339	8560	9875	9218	10634	12152	13770	
Injection pressure	Mpa	215	184	160	138	216	187	162	139	199	172	149	199	173	151	133	
L/D ratio	L/D	21.6	20	21.6	20	22	22	21.6	20	23.6	22	20	23.6	22	22	20	
Injection rate	cm ³ /s	801	934	1078	1252	864	997	1157	1350	1313	1532	1767	1368	1579	1804	2044	
Max. injection speed	mm/s	102				94.3				107				95.6			
Screw stroke	mm	550				570				650				700			
Max. screw speed	r/min	128				112				120				120			
Barrel heating zone	PCS	7				8				8				8			
		CLAMPING UNIT															
Clamping force	kN	18500															
Opening force	kN	1230															
Platen size	mm	2310×2210															
Space between tie bars	mm	1650×1550															
Max. mold thickness	mm	1600															
Min. mold thickness	mm	750															
Opening stroke	mm	2600/1750															
Max. daylight	mm	3350															
Ejector force	kN	460															
Ejector stroke	mm	430															
Ejector number	PCS	33															
		POWER UNIT															
System pressure	MPa	17.5/30				17.5/30				17.5/30				17.5/30			
Pump motor	kW	117.8+7.5				80.1+35.6+7.5				89.5+78.5+11				89.5+78.5+11			
Total power	kW	177.1	177.1	186.2	186.2	189.6	189.6	189.6	193.8	256.7	276.8	276.8	276.8	291.1			
Heating power	kW	51.8	51.8	60.9	60.9	66.4	66.4	66.4	70.6	87.7	97.8	97.8	97.8	112.1			
		GENERAL															
Oil tank capacity	L	1150				1270				1600				1600			
Machine dimensions	m	11.5×3.9×3.5				12.1×3.9×3.5				12.8×3.9×3.5				12.8×3.9×3.5			
Max. mold weight	T	42				42				42				42			

- Opening force refers to mold opening force generated during high-pressure mold open.
- In the case of opening stroke, data before the slash refer to mold opening stroke with minimum mold height and opening stroke with maximum mold height.
- Mold-bearing capacity of the movable platen is 2/3 of total mold weight.
- The shot weight is calculated by GPPS and it is 0.92 times of the theoretical shot volume.
- The medium screw diameter is standard on the machine.
- The injection unit data are in international units and calculated as follows: theoretical shot volume [cm³] × injection pressure [MPa]/100
- The green figures are standard specifications of clamping unit and injection unit.
- Because of constant technical improvement, the machine specifications are subject to change without notice.

Machine Dimensions

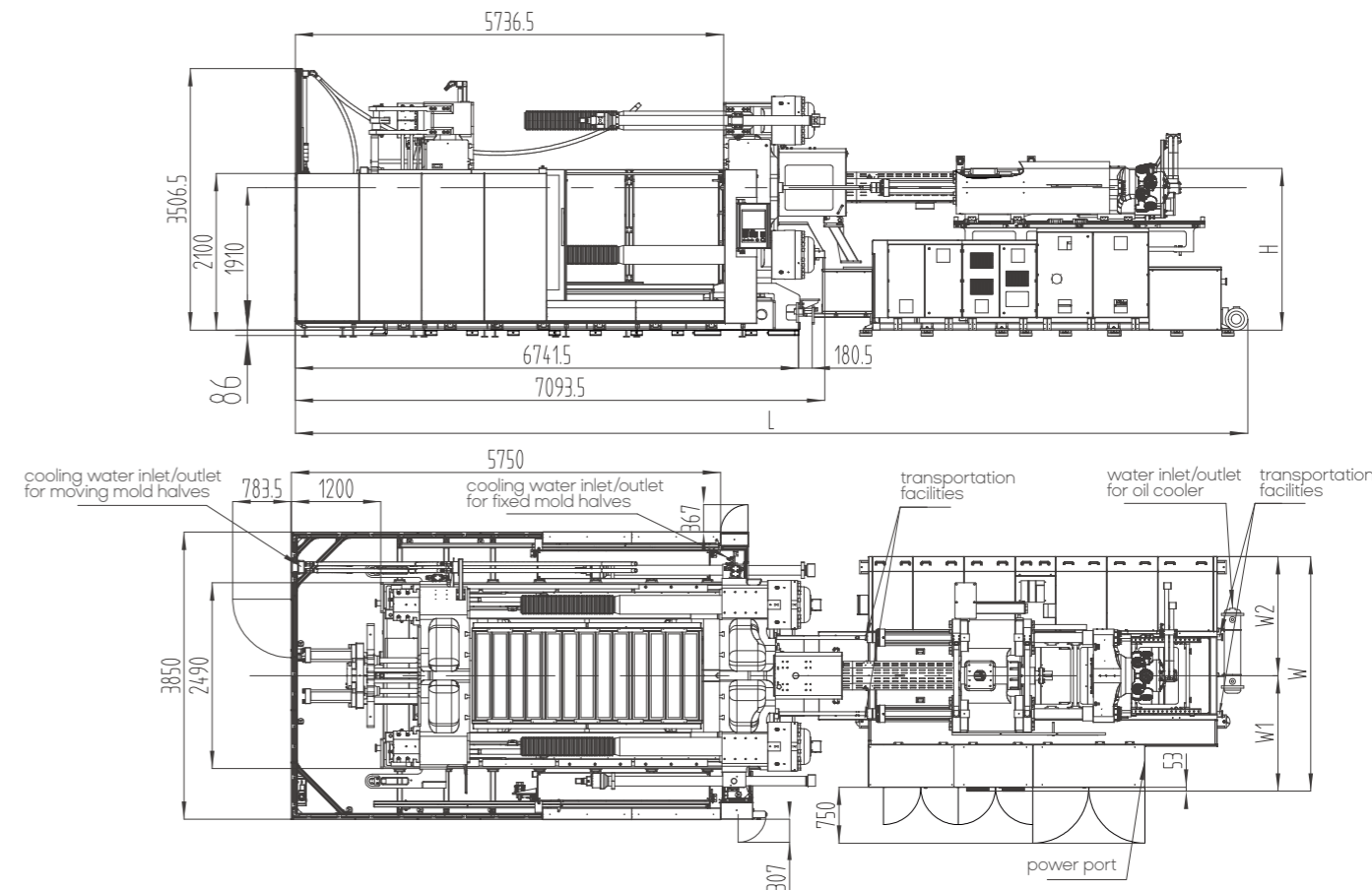

Platen Dimensions

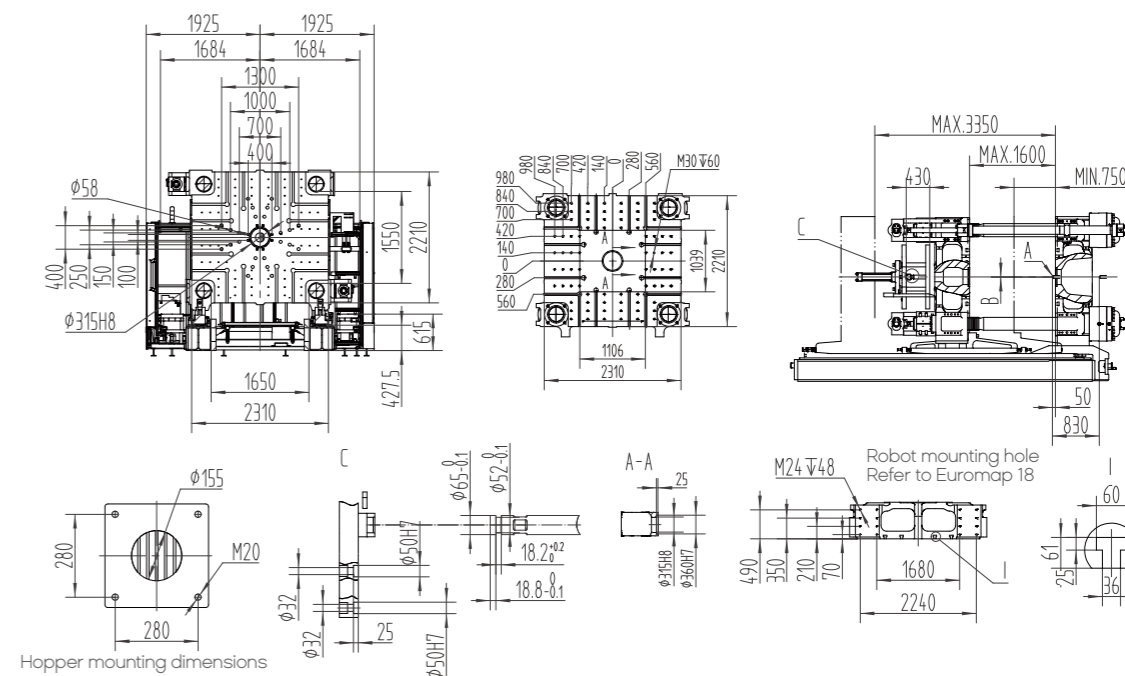

Model	A	B	L	H	W	W1	W2	Main power cord size	Full-load current	Bearing capacity of foundation	Mold cooling water ports	Cooling water flow (mold excluded)	Cooling water pressure	Compressed air pressure
	mm	mm	mm	mm	mm	mm	mm	mm ²	A	t/m ²	n×L/min	L/min	bar	bar
UN1850D1S-IU9300	SR15	Ø4.5	11503.5	2124	2756	1300.5	1455.5	95	337.02	10.5	(8+8)×11	100	3~4	5~6
UN1850D1S-IU11300	SR20	Ø6	12130.5	2144	2906	1450.5	1455.5	120	354.96					
UN1850D1S-IU16000	SR20	Ø8	12757.5	2168	3146	1548	1598	150	498.85					
UN1850D1S-IU20000	SR20	Ø8	12757.5	2183	3146	1548	1598	150	514.15			250		

UN2100D1S Specification

Model		UN2100D1S															
		INJECTION UNIT															
		IU11300				IU16000				IU20000				IU25000		IU40000	
Screw diameter	mm	108	116	125	135	125	135	145	135	145	155	165	155	165	165	185	
Theoretical shot volume	cm ³	5222	6024	6995	8159	7977	9304	10733	10020	11559	13208	14968	14152	16037	20955	26343	
Shot weight	g	4804	5542	6435	7506	7339	8560	9875	9218	10634	12152	13770	13020	14754	19278	24235	
Injection pressure	Mpa	216	187	162	139	199	172	149	199	173	151	133	175	154	190	151	
L/D ratio	L/D	22	22	21.6	20	23.6	22	20	23.6	22	22	20	22	20.1	24	22	
Injection rate	cm ³ /s	864	997	1157	1350	1313	1532	1767	1368	1579	1804	2044	1472	1668	1614	2029	
Max. injection speed	mm/s	94.3				107				95.6				78		75.5	
Screw stroke	mm	570				650				700				750		980	
Max. screw speed	r/min	112				120				120				114		80	
Barrel heating zone	PCS	8				8				8				10		11	
		CLAMPING UNIT															
Clamping force	kN	21000															
Opening force	kN	1380															
Platen size	mm	2620×2320															
Space between tie bars	mm	1800×1600															
Max. mold thickness	mm	1700															
Min. mold thickness	mm	800															
Opening stroke	mm	2700/1800															
Max. daylight	mm	3500															
Ejector force	kN	460															
Ejector stroke	mm	430															
Ejector number	PCS	25															
		POWER UNIT															
System pressure	MPa	17.5/30				17.5/30				17.5/30				17.5/30		17.5/30	
Pump motor	kW	80.1+35.6+7.5				89.5+78.5+11				89.5+78.5+11				89.5+78.5+11		117.8+89.5+11	
Total power	kW	189.6	189.6	189.6	193.8	256.7	276.8	276.8	276.8	291.1	291.4	365.8					
Heating power	kW	66.4	66.4	66.4	70.6	87.7	97.8	97.8	97.8	112.1	112.4	147.5					
		GENERAL															
Oil tank capacity	L	1270				1600				1600				1600		2100	
Machine dimensions	m	12.4×4.2×3.5				13×4.2×3.5				13×4.2×3.5				13×4.2×3.5		15.7×4.2×3.5	
Max. mold weight	T	50				50				50				50		50	

- Opening force refers to mold opening force generated during high-pressure mold open.
- In the case of opening stroke, data before the slash refer to mold opening stroke with minimum mold height and opening stroke with maximum mold height.
- Mold-bearing capacity of the movable platen is 2/3 of total mold weight.
- The shot weight is calculated by GPPS and it is 0.92 times of the theoretical shot volume.
- The medium screw diameter is standard on the machine.
- The injection unit data are in international units and calculated as follows: theoretical shot volume [cm³] × injection pressure (MPa)/100
- The green figures are standard specifications of clamping unit and injection unit.
- Because of constant technical improvement, the machine specifications are subject to change without notice.

Machine Dimensions

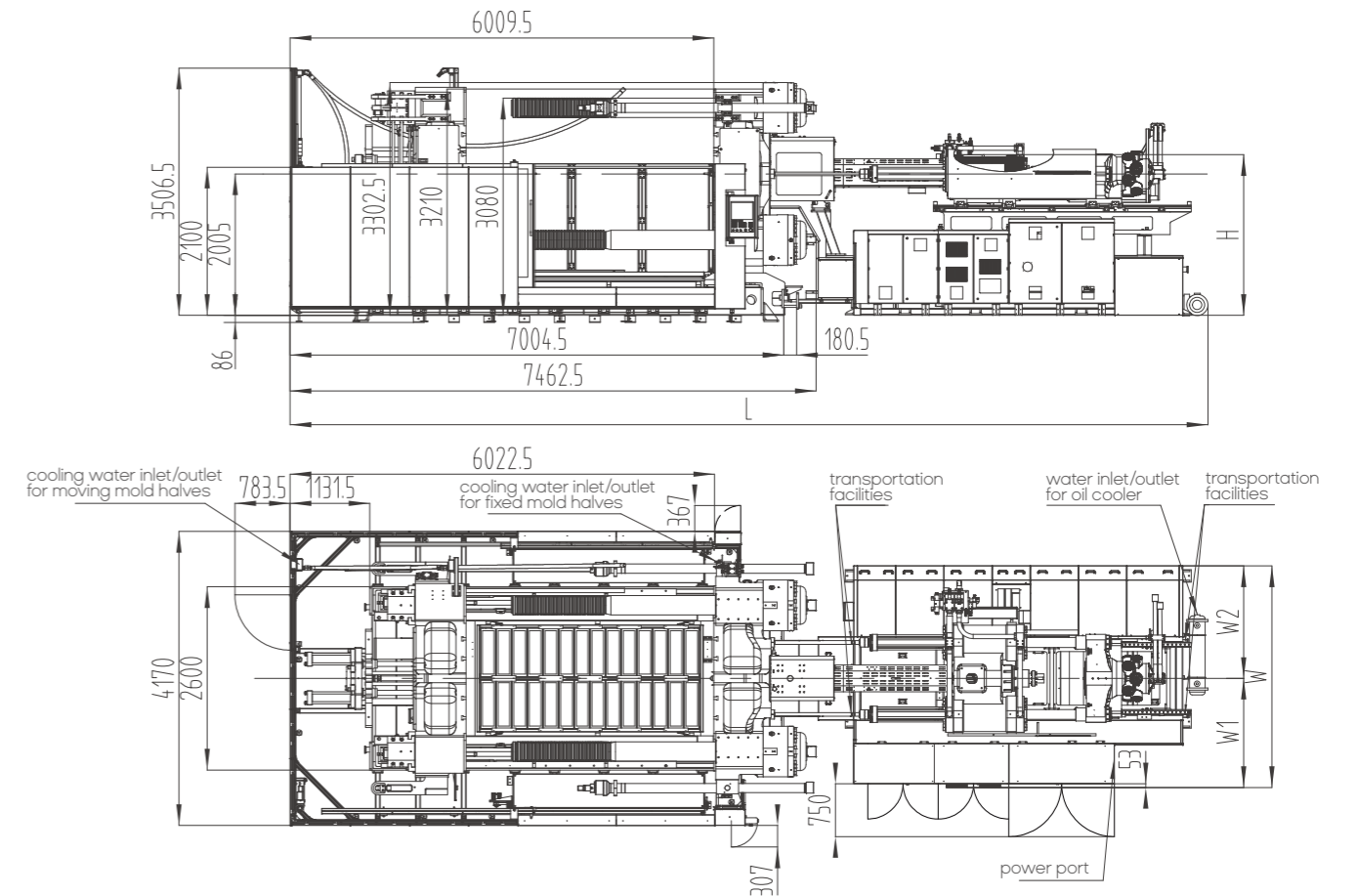

Platen Dimensions

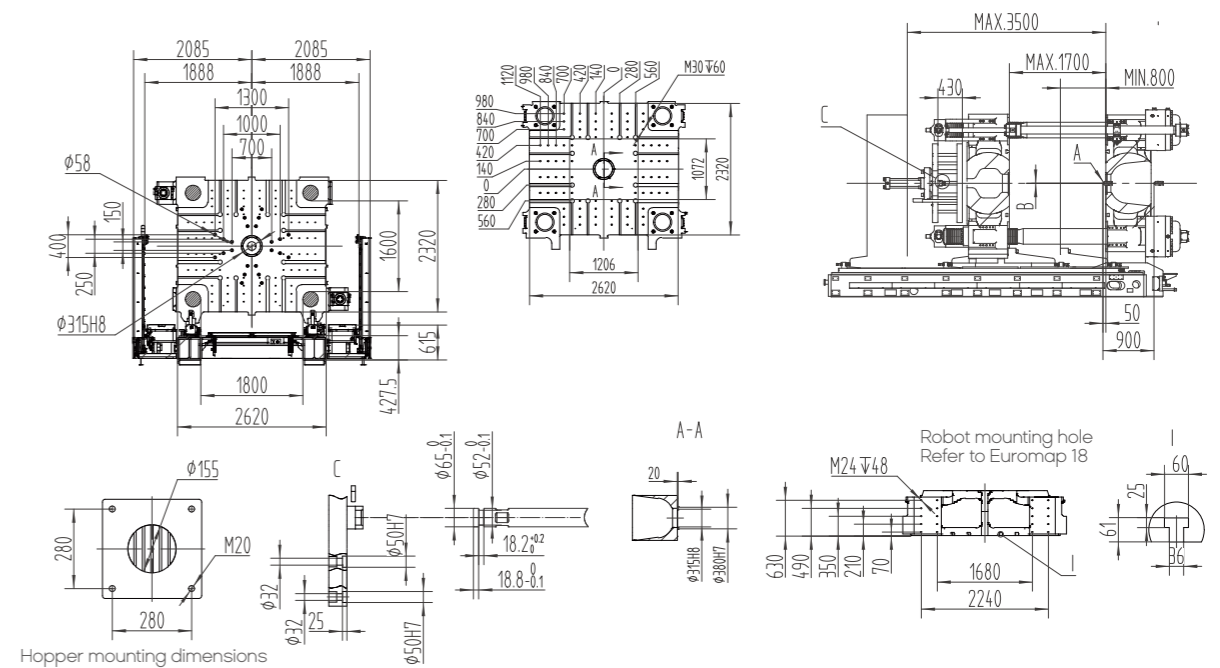

Model	A	B	L	H	W	W1	W2	Main power cord size	Full-load current	Bearing capacity of foundation	Mold cooling water ports	Cooling water flow (mold excluded)	Cooling water pressure	Compressed air pressure
	mm	mm	mm	mm	mm	mm	mm	mm ²	A	t/m ²	n×L/min	L/min	bar	bar
UN2100D1S-IU11300	SR20	Ø6	12393.5	2239	2906	1450.5	1455.5	120	354.96	12.5	(8+8)×11	100	3-4	5-6
UN2100D1S-IU16000	SR20	Ø8	13020.5	2263	3146	1548	1598	150	498.85			250		
UN2100D1S-IU20000	SR20	Ø8	13020.5	2278	3146	1548	1598	150	514.15			350		
UN2100D1S-IU25000	SR25	Ø8	13020.5	2289	3146	1548	1598	185	536.29					
UN2100D1S-IU40000	SR25	Ø8	15655	2325	3661	1848	1813	185	668.08					

UN2850D1S Specification

Model		UN2850D1S									
		INJECTION UNIT									
		IU20000				IU25000		IU40000		IU55600	IU68000
Screw diameter	mm	135	145	155	165	155	165	165	185	200	215
Theoretical shot volume	cm ³	10020	11559	13208	14968	14152	16037	20955	26343	35186	43566
Shot weight	g	9218	10634	12152	13770	13020	14754	19278	24235	32371	40081
Injection pressure	Mpa	199	173	151	133	175	154	190	151	158	156
L/D ratio	L/D	23.6	22	22	20	22	20.1	24	22	22	22
Injection rate	cm ³ /s	1368	1579	1804	2044	1472	1668	1614	2029	2482	2541
Max. injection speed	mm/s	95.6				78	75.5		79	70	
Screw stroke	mm	700				750	980		1120	1200	
Max. screw speed	r/min	120				114	80		85	52	
Barrel heating zone	PCS	8				10	11		9	9	
		CLAMPING UNIT									
Clamping force	kN	28500									
Opening force	kN	2200									
Platen size	mm	2790×2725									
Space between tie bars	mm	2010×1800									
Max. mold thickness	mm	2010									
Min. mold thickness	mm	790									
Opening stroke	mm	3110/1890									
Max. daylight	mm	3900									
Ejector force	kN	460									
Ejector stroke	mm	500									
Ejector number	PCS	33									
		POWER UNIT									
System pressure	MPa	17.5/30				17.5/30	17.5/30	17.5/30	17.5/30	17.5/30	17.5/30
Pump motor	kW	89.5+78.5+11				89.5+78.5+11	117.8+89.5+11		117.8+89.5+56.1+11	117.8+89.5+56.1+11	
Total power	kW	276.8	276.8	276.8	291.1	291.4	365.8		467.4	497.4	
Heating power	kW	97.8	97.8	97.8	112.1	112.4	147.5		193	223	
		GENERAL									
Oil tank capacity	L	1600				1600	2100		3200	3200	
Machine dimensions	m	13.9×4.6×3.6				13.9×4.6×3.6	16.6×4.6×3.6		17.1×4.6×3.6	18.2×4.6×3.6	
Max. mold weight	T	75				75	75		75	75	

- Opening force refers to mold opening force generated during high-pressure mold open.
- In the case of opening stroke, data before the slash refer to mold opening stroke with minimum mold height and opening stroke with maximum mold height.
- Mold-bearing capacity of the movable platen is 2/3 of total mold weight.
- The shot weight is calculated by GPPS and it is 0.92 times of the theoretical shot volume.
- The medium screw diameter is standard on the machine.
- The injection unit data are in international units and calculated as follows: theoretical shot volume [cm³] × injection pressure [MPa]/100
- The green figures are standard specifications of clamping unit and injection unit.
- Because of constant technical improvement, the machine specifications are subject to change without notice.

Machine Dimensions

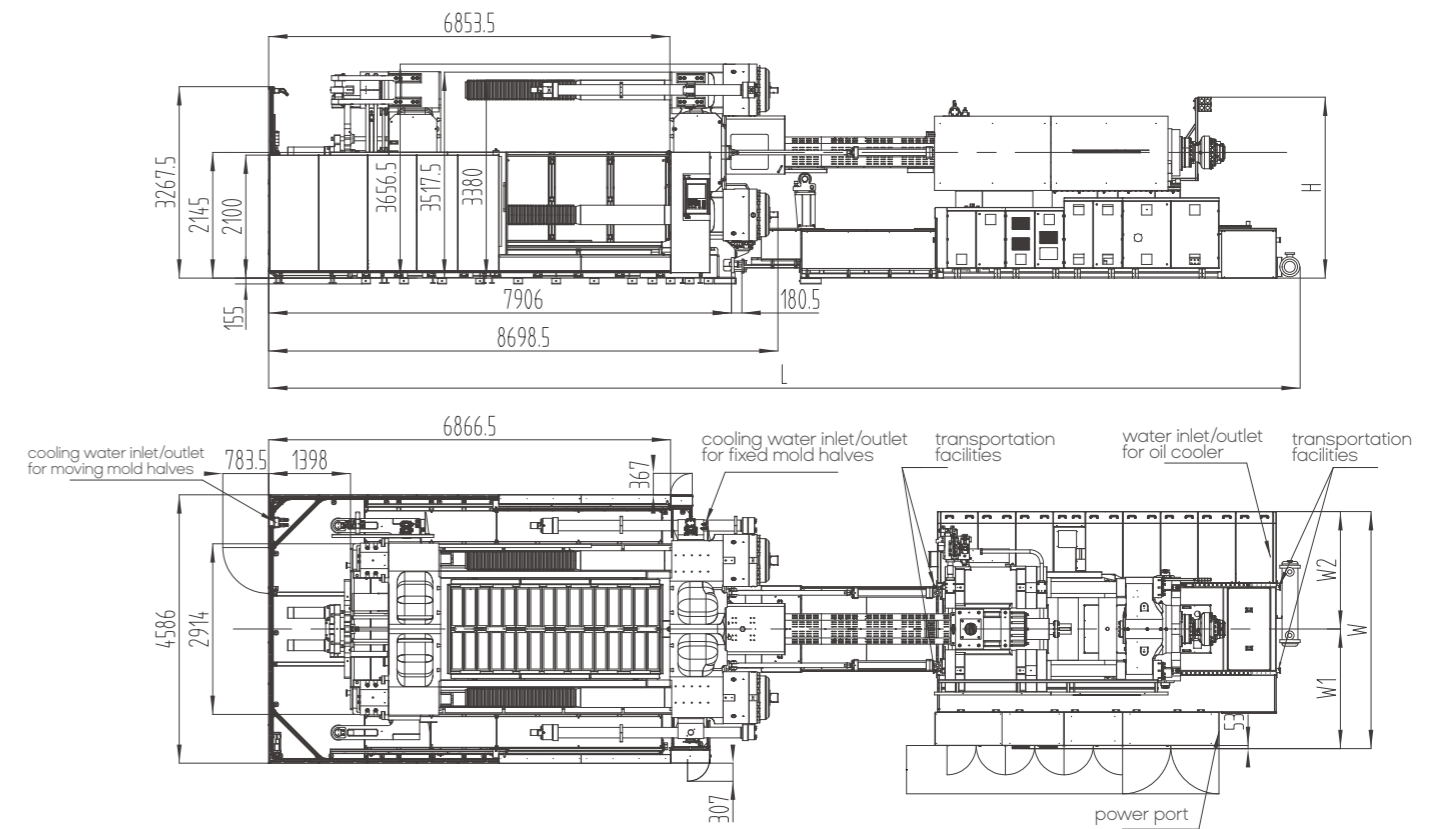

Platen Dimensions

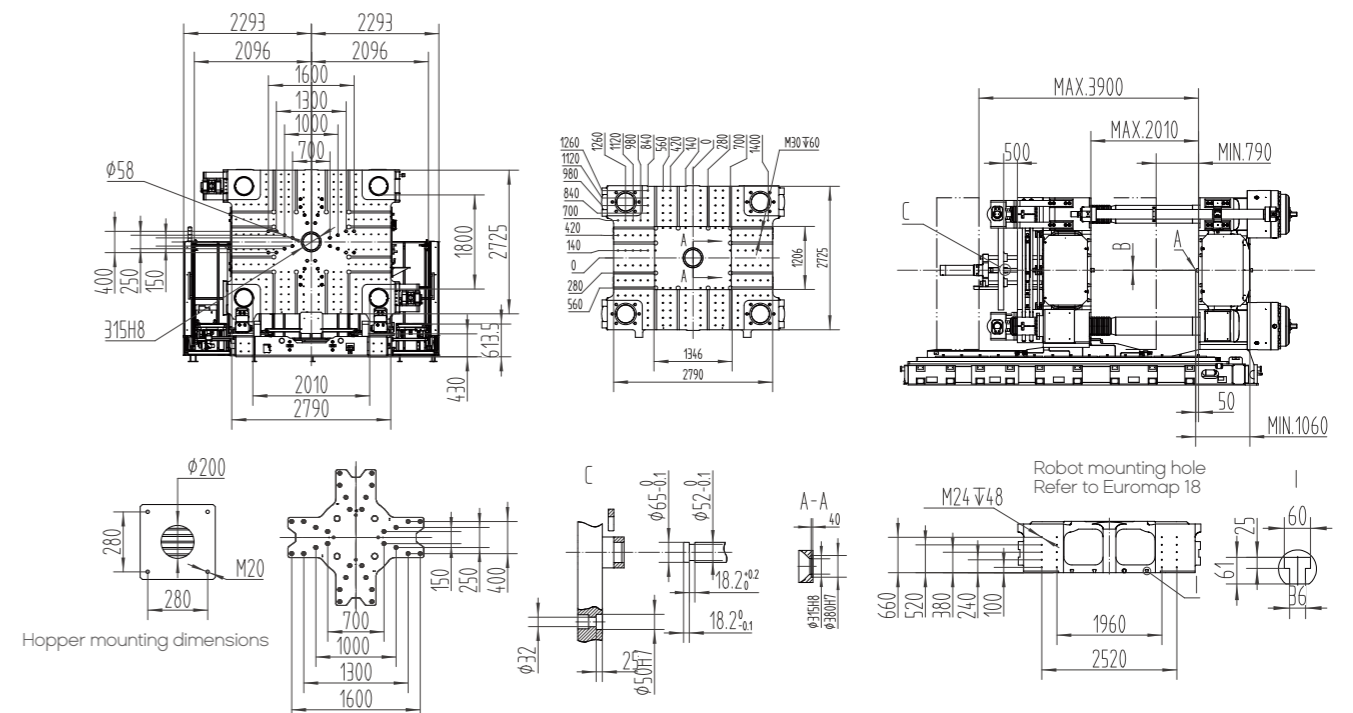

Model	A	B	L	H	W	W1	W2	Main power cord size	Full-load current	Bearing capacity of foundation	Mold cooling water ports	Cooling water flow (mold excluded)	Cooling water pressure	Compressed air pressure
	mm	mm	mm	mm	mm	mm	mm	mm ²	A	t/m ²	n×L/min	L/min	bar	bar
UN2850D1S-IU20000	SR20	Ø8	13922	2373	3146	1548	1598	150	514.15	14.5	(8+8)×11	250	3-4	5-6
UN2850D1S-IU25000	SR25	Ø8	13922	2384	3146	1548	1598	185	536.29					
UN2850D1S-IU40000	SR25	Ø8	16556.5	2420	3661	1848	1813	185	668.08					
UN2850D1S-IU55600	SR28	Ø12	17623.5	2455	4051	2043	2008	185	894.28					
UN2850D1S-IU68000	SR28	Ø12	18214.5	2505	4051	2043	2008	185	940.61					

UN3400D1S Specification

Model		UN3400D1S										
		INJECTION UNIT										
		IU20000				IU25000		IU40000		IU55600		IU68000
Screw diameter	mm	135	145	155	165	155	165	165	185	200	215	
Theoretical shot volume	cm ³	10020	11559	13208	14968	14152	16037	20955	26343	35186	43566	
Shot weight	g	9218	10634	12152	13770	13020	14754	19278	24235	32371	40081	
Injection pressure	Mpa	199	173	151	133	175	154	190	151	158	156	
L/D ratio	L/D	23.6	22	22	20	22	20.1	24	22	22	22	
Injection rate	cm ³ /s	1368	1579	1804	2044	1472	1668	1614	2029	2482	2541	
Max. injection speed	mm/s	95.6				78	75.5		79	70		
Screw stroke	mm	700				750	980		1120	1200		
Max. screw speed	r/min	120				114	80		85	52		
Barrel heating zone	PCS	8				10	11		9	9		
		CLAMPING UNIT										
Clamping force	kN	34000										
Opening force	kN	2550										
Platen size	mm	3220×2810										
Space between tie bars	mm	2240×1900										
Max. mold thickness	mm	2000										
Min. mold thickness	mm	1100										
Opening stroke	mm	3100/2200										
Max. daylight	mm	4200										
Ejector force	kN	460										
Ejector stroke	mm	500										
Ejector number	PCS	33										
		POWER UNIT										
System pressure	MPa	17.5/30				17.5/30	17.5/30	17.5/30	17.5/30	17.5/30		
Pump motor	kW	89.5+78.5+11				89.5+78.5+11	117.8+89.5+11	117.8+89.5+56.1+11	117.8+89.5+56.1+11			
Total power	kW	276.8	276.8	276.8	291.1	291.4	365.8	467.4	497.4			
Heating power	kW	97.8	97.8	97.8	112.1	112.4	147.5	193	223			
		GENERAL										
Oil tank capacity	L	1600				1600	2100	3200	3200			
Machine dimensions	m	14.5×4.9×3.9				14.5×4.9×3.9	17.2×4.9×3.9	17.7×4.9×3.9	18.8×4.9×3.9			
Max. mold weight	T	81				81	81	81	81			

- Opening force refers to mold opening force generated during high-pressure mold open.
- In the case of opening stroke, data before the slash refer to mold opening stroke with minimum mold height and opening stroke with maximum mold height.
- Mold-bearing capacity of the movable platen is 2/3 of total mold weight.
- The shot weight is calculated by GPPS and it is 0.92 times of the theoretical shot volume.
- The medium screw diameter is standard on the machine.
- The injection unit data are in international units and calculated as follows: theoretical shot volume [cm³] × injection pressure [MPa]/100
- The green figures are standard specifications of clamping unit and injection unit.
- Because of constant technical improvement, the machine specifications are subject to change without notice.

Machine Dimensions

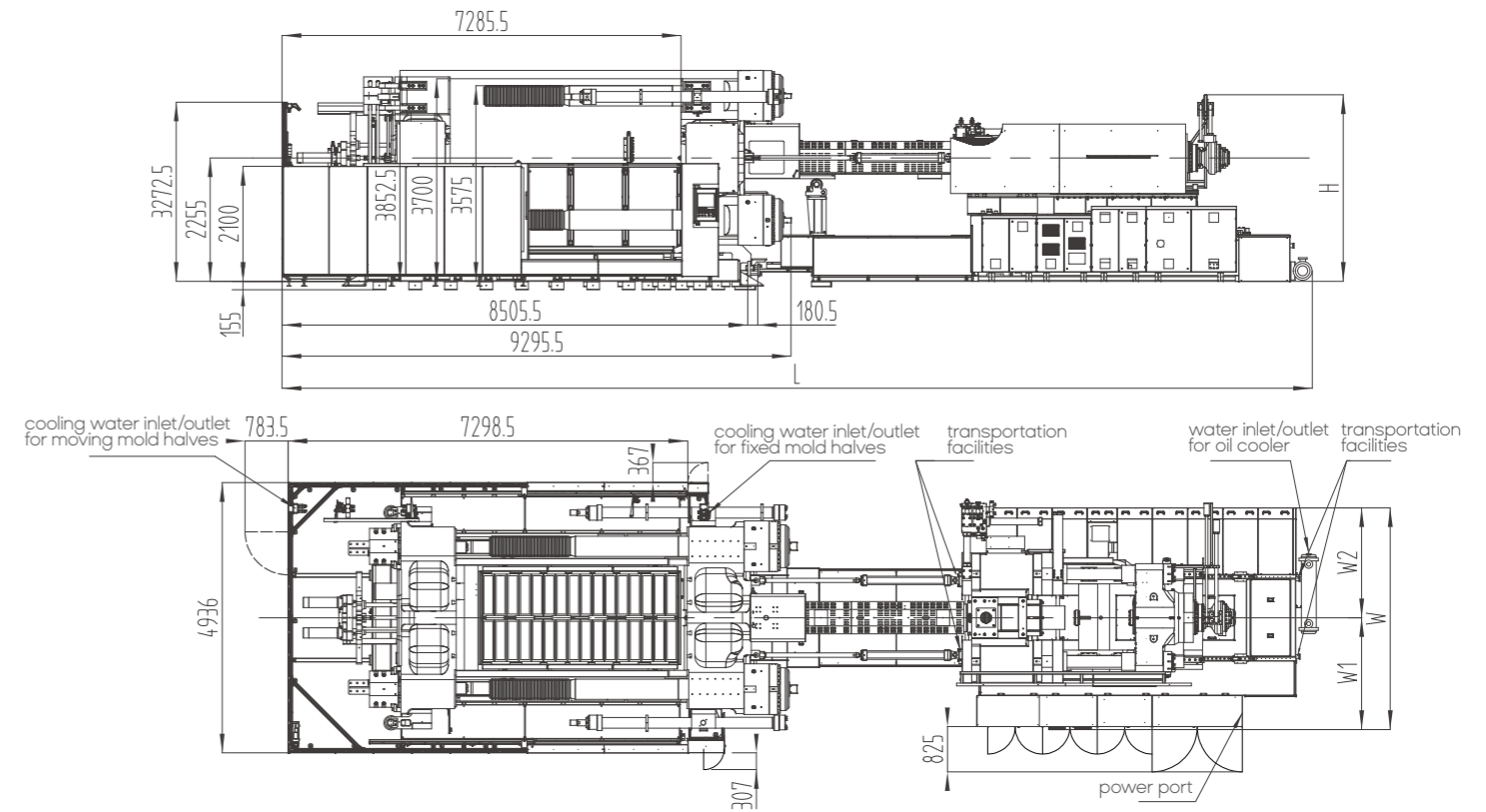

Platen Dimensions

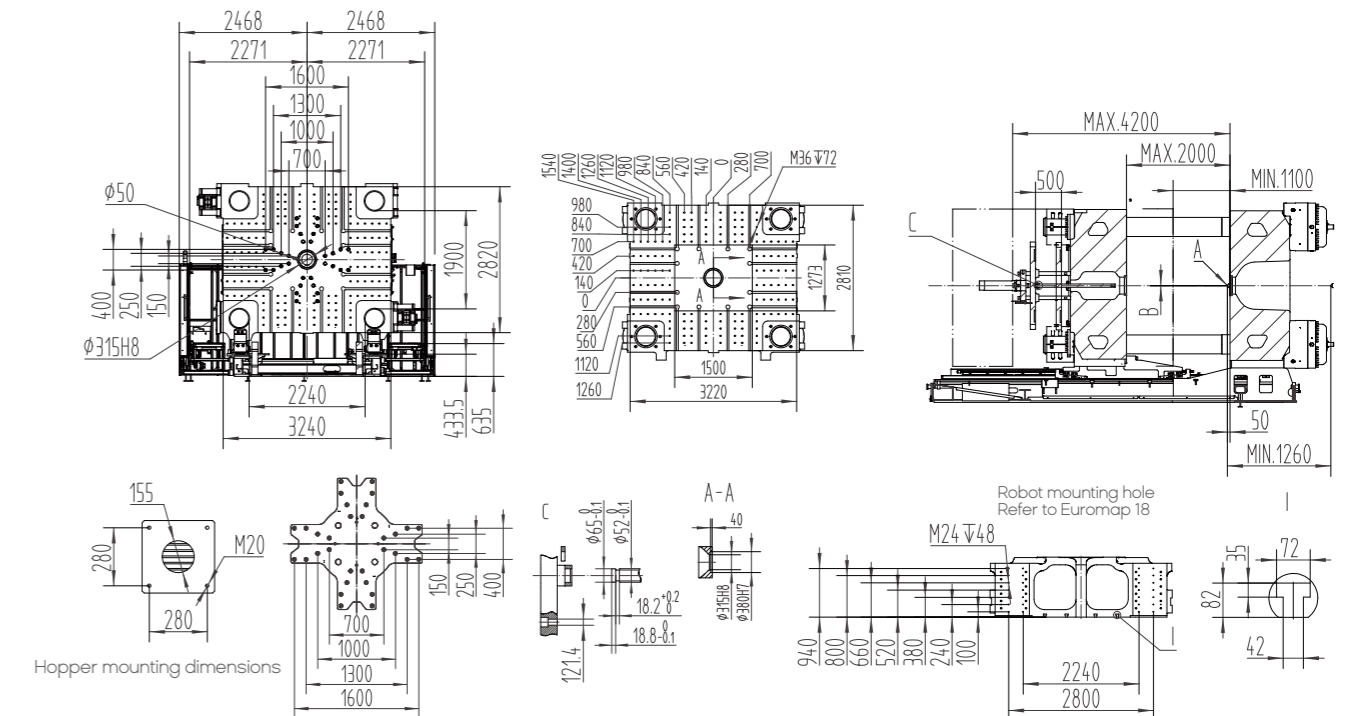

Model	A	B	L	H	W	W1	W2	Main power cord size	Full-load current	Bearing capacity of foundation	Mold cooling water ports	Cooling water flow (mold excluded)	Cooling water pressure	Compressed air pressure
	mm	mm	mm	mm	mm	mm	mm	mm ²	A	t/m ²	n×L/min	L/min	bar	bar
UN3400D1S-IU20000	SR20	Ø8	14521.5	2373	3146	1548	1598	150	514.15	14.5	(8+8)×11	250	3-4	5-6
UN3400D1S-IU25000	SR25	Ø8	14521.5	2384	3146	1548	1598	185	536.29					
UN3400D1S-IU40000	SR25	Ø8	17156	2420	3661	1848	1813	185	668.08					
UN3400D1S-IU55600	SR28	Ø12	18223	2455	4051	2043	2008	185	894.28					
UN3400D1S-IU68000	SR28	Ø12	18814	2505	4051	2043	2008	185	940.61					

Standard and Optional Features

● Standard ○ Optional

CLAMPING UNIT		
Clamping mechanism with tie bars independent of moving platen	●	
Quantitative volumetric automatic lubrication	●	
High-response proportional control of pressure and flow for mold open & mold close	●	
Hydraulically-driven ejection device	●	
Low-pressure mold protection	●	
Clamping force adjustment as needed	●	
Forced reset function	●	
Ejector return protection	●	
Robot mounting hole (Euromap 18)	●	
Electric door (optional for 550T-1400T machine)	●	
T-slot platen	●	
Four clamp platens made of high-rigidity ductile iron	●	
Hydraulic and electrical safety devices	●	
Safety foot plate in mold area (optional for 550 or 750T machine)	●	
High-accuracy magnetostrictive displacement sensor for mold open/close control	●	
Mold spring	●	
Safety foot plate in front & rear door areas		○
Synchronous ejection and core pulling		○
Secondary mold closing		○
Quick mold change system platform		○
Hydraulic mold clamp		○
Magnetic platen		○
Increased mold thickness		○
Increased ejector stroke		○
Mold lifting device		○
Heat insulating plate of mold		○
Special mold mounting hole		○
Increased mold opening stroke		○
Larger ejection force		○
ELECTRIC CONTROL SYSTEM		
Closed-loop PID barrel temperature control	●	
Manual, semi-auto and fully-auto operating mode	●	
Input and output inspection interface	●	
Automatic display of alarm messages and acousto-optic alarm system	●	
Built-in software with the oscilloscope function	●	
Unlimited technical parameter storage	●	
Automatic mold height adjustment	●	
Chinese and English operating system	●	
Safety gate emergency stop function	●	
Online cycle monitoring	●	
15" TFT color touch screen	●	
Visualized graphic programming	●	
PDP interface	●	
Injection monitoring protection	●	
Mold-close monitoring protection	●	
Statistical process control (SPC) interface	●	
Electrical enclosure rated IP54	●	
Screw speed detecting device	●	
Time/ position/ time + position control modes for switchover to holding phase	●	
Protective plate in mold area	●	
3 sets of 380V 32A socket (2 sets standard for UN550-900D1S machine)	●	
1 set of 380V 16A socket (2 sets standard for UN750-900D1S machine)	●	
16-level password security	●	
Reserved robot interfaces based on SPI, EUROMAP 12	●	
Automatic heat preserving, automatic heating settings	●	
Servo injection		○
Electric unscrewing device		○
Hot runner interface		○
Auxiliary emergency stop button		○
Air blast in mold		○
Power supply change		○

● Standard ○ Optional

Central (networked) monitoring system		○
Protective light grid of safety gates		○
Opto-electronic safety switch of front and rear safety gates		○
Protective light grid of central safety foot plate		○
INJECTION UNIT		
Double parallel cylinder injection unit with low-speed high-torque hydraulic motor	●	
Nitride alloy steel screw & barrel	●	
Purge guard (with electrical protection)	●	
Selectable suck-back before or after plasticizing	●	
10-stage injection speed/ pressure/ position control	●	
10-stage holding speed/ pressure/ position/ time control	●	
5-stage plasticizing speed/ pressure/ position/ time control	●	
Linear guides for injection unit	●	
Double-carriage cylinder	●	
Cold start protection	●	
Manual central lubrication system of injection unit	●	
Suck back function	●	
Automatic purging	●	
Screw rotation measuring device	●	
Injection carriage transducer		○
Mixing screw		○
Bi-metallic screw barrel		○
Swivelling injection unit		○
Extended nozzle (50/100/150/200mm longer)		○
Special screw components		○
Energy-saving barrel heat retaining device (silicone cover)		○
Spring shut-off nozzle		○
Increased injection stroke		○
HYDRAULIC SYSTEM		
Low-noise energy-saving hydraulic circuit	●	
Proportional back pressure control for plasticizing	●	
Oil pre-heating system	●	
2 sets of core pull (standard: 1 set for UN550D1S, 4 sets for UN2100/2400D1S, 6 sets for UN2850/3400/4000D1S)	●	
Differential mold-open circuit	●	
Injection and mold-close pressure protection	●	
High-pressure mold opening	●	
Automatic pressure and flow calibration	●	
Oil temperature and oil level alarm	●	
High-performance servo pump system	●	
Multiple sets of sequence (injection) valve interface		○
Variable displacement pump system		○
Closed-loop proportional variable displacement pump system		○
High-response accumulating servo injection system		○
Enlarged oil cooler		○
Multi-capacity larger pump motor		○
Multi-capacity larger plasticizing motor		○
Servo injection (closed-loop control of injection, plasticizing, holding pressure and back pressure)		○
Plasticizing during mold opening		○
Multiple sets of core pull or unscrewing devices with electrical interfaces		○
OTHER		
User manual	●	
Adjustable leveling pad	●	
8-in 8-out water manifold on platen (with general, quick connectors)	●	
Nozzle spanner	●	
Mold clamp	●	
Hopper		○
Hydraulic oil (standard for UN550-1400D1S)		○
Loading platform		○
Mold temperature controller		○
Automatic loader		○
Dehumidification dryer		○

YIZUO

THINK
TECH FORWARD